

NFX150 Network Services Platform Hardware Guide

Published
2024-05-29

Juniper Networks, Inc.
1133 Innovation Way
Sunnyvale, California 94089
USA
408-745-2000
www.juniper.net

Juniper Networks, the Juniper Networks logo, Juniper, and Junos are registered trademarks of Juniper Networks, Inc. in the United States and other countries. All other trademarks, service marks, registered marks, or registered service marks are the property of their respective owners.

Juniper Networks assumes no responsibility for any inaccuracies in this document. Juniper Networks reserves the right to change, modify, transfer, or otherwise revise this publication without notice.

NFX150 Network Services Platform Hardware Guide
Copyright © 2024 Juniper Networks, Inc. All rights reserved.

The information in this document is current as of the date on the title page.

YEAR 2000 NOTICE

Juniper Networks hardware and software products are Year 2000 compliant. Junos OS has no known time-related limitations through the year 2038. However, the NTP application is known to have some difficulty in the year 2036.

END USER LICENSE AGREEMENT

The Juniper Networks product that is the subject of this technical documentation consists of (or is intended for use with) Juniper Networks software. Use of such software is subject to the terms and conditions of the End User License Agreement ("EULA") posted at <https://support.juniper.net/support/eula/>. By downloading, installing or using such software, you agree to the terms and conditions of that EULA.

Table of Contents

About This Guide | viii

1

Overview

NFX150 Network Services Platform Overview | 2

NFX150 Chassis | 10

Front Panel of an NFX150 Device | 10

Rear Panel of an NFX150 Device | 16

LED Details of an NFX150 Device | 20

Chassis Status LEDs | 20

Network Port and Uplink Port LEDs | 22

Management Port LEDs | 23

LTE Module LEDs | 24

NFX150 Interface Modules | 26

LTE on NFX Devices | 26

Overview | 26

Features Supported on the LTE Module for NFX Devices | 27

Understanding the LTE Physical Interface | 28

Understanding the LTE Logical Interface | 28

LTE Expansion Module (NFX-LTE-AE and NFX-LTE-AA) | 29

NFX-EM-6T2SFP Expansion Module | 32

NFX150 Cooling System | 33

NFX150 Power System | 34

Power Supply in NFX150 Devices | 35

AC Power Supply Specifications for an NFX150 Device | 35

AC Power Cord Specifications for an NFX150 Device | 35

2

Site Planning, Preparation, and Specifications

Site Preparation Checklist for NFX150 Devices | 40

NFX150 Site Guidelines and Requirements | 42

General Site Guidelines | 43

Chassis Physical Specifications for an NFX150 Device | 43

Environmental Requirements and Specifications for an NFX150 Device | 44

Site Electrical Wiring Guidelines | 45

Clearance Requirements for Airflow and Hardware Maintenance for an NFX150 Device | 46

Requirements for Mounting an NFX150 Device on a Desktop or Other Level Surface | 49

Requirements for Mounting an NFX150 Device on a Wall | 49

Rack Requirements for NFX150 Devices | 49

Cabinet Requirements for an NFX150 Device | 51

NFX150 Network Cable and Transceiver Planning | 52

Pluggable Transceivers Supported on NFX150 Devices | 53

SFP+ Direct Attach Cables for NFX150 Devices | 54

Understanding NFX150 Devices Fiber-Optic Cable Signal Loss, Attenuation, and Dispersion | 55

Calculating the Fiber-Optic Cable Power Budget for an NFX150 Device | 57

Calculating the Fiber-Optic Cable Power Margin for an NFX150 Device | 58

NFX150 Cable Specifications and Pinouts | 60

Cable Specifications for Console and Management Connections for the NFX150 Devices | 60

Mini-USB Type-B Console Port Specifications for an NFX150 Device | 61

Console Port Connector Pinouts for NFX150 Devices | 62

USB Port Specifications for an NFX150 Device | 63

Management Port Connector Pinout Information for an NFX150 Device | 64

Network Port Connector Pinout Information for an NFX150 Device | 65

RJ-45 to DB-9 Serial Port Adapter Pinout Information for an NFX150 Device | 67

Initial Installation and Configuration

NFX150 Installation Overview | 69

Unpacking and Mounting the NFX150 | 70

- Unpacking an NFX150 Device | 70
- Parts Inventory (Packing List) for an NFX150 Device | 71
- Register Products—Mandatory to Validate SLAs | 72
- Mounting an NFX150 Device | 73
- Mounting an NFX150 Device on a Desk or Other Level Surface | 74
- Mounting an NFX150 Device on a Wall | 76
- Mounting an NFX150 Device on Two Posts in a Rack | 80
- Mounting an NFX150 Device on Four Posts in a Rack or Cabinet | 83

Connecting the NFX150 to Power | 85

- Connecting Earth Ground to an NFX150 Device | 86
- Connecting AC Power to an NFX150 Device | 88

Connecting the NFX150 to the Network | 90

- Connecting an NFX150 Device to a Network for Out-of-Band Management | 90
- Connecting an NFX150 Device to a Management Console | 91
- Connecting an NFX150 Device to a Management Console Using Mini-USB Type-B Console Port | 93
- Installing a Transceiver in an NFX150 Device | 94
- Connecting a Fiber-Optic Cable to an NFX150 Device | 96

Initial Configuration on NFX150 Devices | 98

- Factory-Default Settings | 98
- Enabling Basic Connectivity | 100
- Establishing the Connection | 102

Installing and Configuring the NFX150 Expansion Modules | 103

- Installing the Expansion Module | 103
- Installing the LTE Expansion Module | 104
- Configuring the LTE Expansion Module | 105

- Configuring the LTE Expansion Module for Primary Mode | 106
- Configuring the LTE Expansion Module for Dial-on-Demand Mode | 108
- Configuring the LTE Expansion Module for Backup Mode | 110
- Upgrading the Modem Firmware on NFX Devices Through Over-the-Air (OTA) | 112

4

Maintaining Components

Maintaining Transceivers on the NFX150 | 116

- Installing a Transceiver in an NFX150 Device | 116
- Removing a Transceiver from an NFX150 Device | 118

Maintaining Fiber-Optic Cables on the NFX150 | 120

- Maintaining Fiber-Optic Cables in an NFX150 Device | 120
- Disconnecting a Fiber-Optic Cable from an NFX150 Device | 121
- Connecting a Fiber-Optic Cable to an NFX150 Device | 122

Removing the NFX150 Device from a Rack or Cabinet | 123

- Powering off an NFX150 Device | 123
- Removing an NFX150 Device from a Rack or Cabinet | 125

5

Troubleshooting Hardware

Understanding Alarm Types and Severity Levels on NFX150 Devices | 128

6

Contacting Customer Support and Returning the Chassis or Components

Returning the NFX150 Chassis or Components | 131

- Returning a NFX150 Device or Component for Repair or Replacement | 131
- Locating the Serial Number on an NFX150 Device | 132
 - Listing the Device and Components Details with the CLI | 132
 - Locating the Chassis Serial Number ID Label on an NFX150 Device | 133
- Contacting Customer Support to Obtain a Return Materials Authorization for an NFX150 Device | 133
- Packing an NFX150 Device or Component for Shipping | 135
 - Packing a NFX150 Device for Shipping | 135
 - Packing NFX150 Device Components for Shipping | 136

Safety and Compliance Information

General Safety Guidelines and Warnings | 139

Definitions of Safety Warning Levels | 140

Qualified Personnel Warning | 142

Warning Statement for Norway and Sweden | 142

Fire Safety Requirements | 143

Installation Instructions Warning | 144

Chassis Lifting Guidelines for NFX150 Devices | 145

Restricted Access Warning | 145

Ramp Warning | 146

Rack-Mounting and Cabinet-Mounting Warnings | 147

Laser and LED Safety Guidelines and Warnings for the NFX150 Devices | 151

Radiation from Open Port Apertures Warning | 157

Maintenance and Operational Safety Guidelines and Warnings | 158

General Electrical Safety Guidelines and Warnings | 163

Action to Take After an Electrical Accident | 165

Prevention of Electrostatic Discharge Damage | 165

AC Power Electrical Safety Guidelines | 167

AC Power Disconnection Warning | 168

TN Power Warning | 169

Agency Approvals for NFX150 Devices | 170

Compliance Statements for EMC Requirements for NFX150 Devices | 171

About This Guide

Use this guide to install hardware and perform initial software configuration, routine maintenance, and troubleshooting for the NFX150 Series devices. After completing the installation and basic configuration procedures covered in this guide, refer to the Getting Started with NFX150 Network Services Platform guide for information about further software configuration.

RELATED DOCUMENTATION

[NFX150-C-S1 Quick Start Guide](#)

[NFX150-S1 Quick Start Guide](#)

1

CHAPTER

Overview

NFX150 Network Services Platform Overview | 2

NFX150 Chassis | 10

NFX150 Interface Modules | 26

NFX150 Cooling System | 33

NFX150 Power System | 34

NFX150 Network Services Platform Overview

IN THIS SECTION

- [NFX150 Hardware | 2](#)
- [System Software | 3](#)
- [Junos OS Releases Supported on NFX Series Hardware | 3](#)
- [NFX150 Device Models | 4](#)
- [Benefits and Uses of NFX150 | 10](#)

The Juniper Networks NFX150 Network Services Platform is a secure, automated, software-driven customer premises equipment (CPE) platform that delivers virtualized network and security services on demand. Leveraging Network Functions Virtualization (NFV) and built on the Juniper Cloud CPE solution, NFX150 enables service providers to deploy and chain multiple, secure, high-performance virtualized network functions (VNFs) on a single device.

The NFX150 is suited for small to medium-sized enterprises. With key security features and NFV, the NFX150 can be used in secure SD-WAN and secure router deployments.

This topic covers:

NFX150 Hardware

The NFX150 portfolio consists of a compact desktop model and a rack-mount model. Both the models are available with or without LTE support.

The NFX150 device has four 1-GbE RJ-45 ports which can be used as either access ports or as uplinks, two SFP ports, two SFP+ ports, and one management port. The NFX150 device has a 1 U form factor and comes with built-in fans and power supply.

The NFX150 device can be used as:

- An integrated branch router and switch, extensible with VNFs.
- A CPE for service providers.
- A secure router for distributed enterprises.

System Software

The NFX150 architecture integrates routing, switching, and security functions on a single platform that optimizes the usage of system resources. The architecture enables unified management of all the components through a single CLI. Key components in the NFX150 software include the Junos Control Plane (JCP), Juniper Device Manager (JDM), Layer 2 dataplane, Layer 3 dataplane, and Virtual Network Functions (VNFs). The JCP is the Junos virtual machine (VM) running on the host OS, Wind River Linux. The JCP functions as the single point of management for all the components. The JCP CLI is displayed when you log in to the NFX150 device.

Junos OS Releases Supported on NFX Series Hardware

The following table provides details of Junos OS software releases supported on the NFX Series platforms:

Table 1: Supported Junos OS Releases on NFX Series Devices

NFX Series Platform	Supported Junos OS Release	Software Package	Software Downloads Page
NFX150	18.1R1 or later	nfx-3 jinstall-host-nfx-3-x86-64- <i><release-number></i> -secure-signed.tgz install-media-host-usb-nfx-3-x86-64- <i><release-number></i> -secure.img	NFX150 Software Download Page
NFX250	15.1X53-D45, 15.1X53-D47, 15.1X53-D470, and 15.1X53-D471	nfx-2 jinstall-host-nfx-2-flex-x86-64- <i><release-number></i> -secure-signed.tgz install-media-host-usb-nfx-2-flex-x86-64- <i><release-number></i> -secure.img	NFX250 Software Download Page

Table 1: Supported Junos OS Releases on NFX Series Devices (Continued)

NFX Series Platform	Supported Junos OS Release	Software Package	Software Downloads Page
	17.2R1 through 19.1R1		
	19.1 R1 or later	nfx-3 jinstall-host-nfx-3-x86-64-<release-number>-secure-signed.tgz install-media-host-usb-nfx-3-x86-64-<release-number>-secure.img	NFX250 Software Download Page
NFX350	19.4 R1 or later	nfx-3 jinstall-host-nfx-3-x86-64-<release-number>-secure-signed.tgz install-media-host-usb-nfx-3-x86-64-<release-number>-secure.img	NFX350 Software Download Page

NFX150 Device Models

The NFX150 device is available in five compact models and two rack mount models, with or without LTE support. All models are shipped with built-in AC power supply and have airflow-out (front-to-back) cooling.

The NFX150 is available in seven models. [Table 2 on page 5](#) lists the NFX150-C models and [Table 3 on page 6](#) lists the NFX150-S1 models.

Table 2: NFX150-C (Compact Models)

	NFX150-C-S1	NFX150-C-S1-AE	NFX150-C-S1-AA	NFX150-C-S1E-AE	NFX150-C-S1E-AA
CPU	2.2-GHz 4-core Intel CPU	2.2-GHz 4-core Intel CPU	2.2-GHz 4-core Intel CPU	2.2-GHz 4-core Intel CPU	2.2-GHz 4-core Intel CPU
RAM	8 GB	8 GB	8 GB	16 GB	16 GB
Storage	100 GB SSD	100 GB SSD	100 GB SSD	100 GB SSD	100 GB SSD
Form Factor	Desktop	Desktop	Desktop	Desktop	Desktop
Ports	Four 10/100/1000BASE-T RJ-45 ports which can be used as either access ports or uplinks	Four 10/100/1000BASE-T RJ-45 ports which can be used as either access ports or uplinks	Four 10/100/1000BASE-T RJ-45 ports which can be used as either access ports or uplinks	Four 10/100/1000BASE-T RJ-45 ports which can be used as either access ports or uplinks	Four 10/100/1000BASE-T RJ-45 ports which can be used as either access ports or uplinks
	Two 1-Gigabit Ethernet /10-Gigabit Ethernet SFP+ ports	Two 1-Gigabit Ethernet /10-Gigabit Ethernet SFP+ ports	Two 1-Gigabit Ethernet /10-Gigabit Ethernet SFP+ ports	Two 1-Gigabit Ethernet /10-Gigabit Ethernet SFP+ ports	Two 1-Gigabit Ethernet /10-Gigabit Ethernet SFP+ ports
	One 10/100/1000BASE-T RJ-45 management port	One 10/100/1000BASE-T RJ-45 management port	One 10/100/1000BASE-T RJ-45 management port	One 10/100/1000BASE-T RJ-45 management port	One 10/100/1000BASE-T RJ-45 management port
	Console ports (RJ-45 and mini-USB)	Console ports (RJ-45 and mini-USB)	Console ports (RJ-45 and mini-USB)	Console ports (RJ-45 and mini-USB)	Console ports (RJ-45 and mini-USB)

Table 2: NFX150-C (Compact Models) (Continued)

	NFX150-C-S1	NFX150-C-S1-AE	NFX150-C-S1-AA	NFX150-C-S1E-AE	NFX150-C-S1E-AA
	One USB 3.0 port	One USB 3.0 port	One USB 3.0 port	One USB 3.0 port	One USB 3.0 port
Expansion module support	No	No	No	No	No
LTE support	No	Yes (integrated LTE modem for Europe and North America)	Yes (integrated LTE modem for Asia, Australia, and New Zealand)	Yes (integrated LTE modem for Europe and North America)	Yes (integrated LTE modem for Asia, Australia, and New Zealand)

Table 3: NFX150-S1 Models

	NFX150-S1	NFX150-S1E
CPU	2.2 GHz 8-core Intel CPU	2.2 GHz 8-core Intel CPU
RAM	16 GB	32 GB
Storage	200 GB SSD	200 GB SSD
Form Factor	1 RU	1 RU
Ports	Four 10/100/ 1000BASE-T RJ-45 ports which can be used as either access ports or uplinks	Four 10/100/ 1000BASE-T RJ-45 ports which can be used as either access ports or uplinks
	Two 1-Gigabit Ethernet/10-Gigabit Ethernet SFP+ ports	Two 1-Gigabit Ethernet/10-Gigabit Ethernet SFP+ ports

Table 3: NFX150-S1 Models (Continued)

	NFX150-S1	NFX150-S1E
	One 10/100/ 1000BASE-T RJ-45 management port	One 10/100/ 1000BASE-T RJ-45 management port
	Console ports (RJ-45 and mini-USB)	Console ports (RJ-45 and mini-USB)
	One USB 3.0 port	One USB 3.0 port
LTE support	Yes (LTE expansion module)	Yes (LTE expansion module)
Expansion module support	Yes	Yes
Supported expansion modules NOTE: You can install only one expansion module on the NFX150-S1 devices. The expansion module must be installed in the first slot, which is next to the chassis LEDs.	<ul style="list-style-type: none"> • NFX-EM-6T2SFP— Expansion module with six 1-Gigabit Ethernet RJ-45 ports and two 1-Gigabit Ethernet SFP ports • NFX-LTE-AE—Expansion module with an LTE modem supporting the frequency bands in Europe and North America. • NFX-LTE-AA—Expansion module with an LTE modem supporting the frequency bands in Asia, Australia, and New Zealand. 	<ul style="list-style-type: none"> • NFX-EM-6T2SFP— Expansion module with six 1-Gigabit Ethernet RJ-45 ports and two 1-Gigabit Ethernet SFP ports • NFX-LTE-AE—Expansion module with an LTE modem supporting the frequency bands in Europe and North America. • NFX-LTE-AA—Expansion module with an LTE modem supporting the frequency bands in Asia, Australia, and New Zealand.

Figure 1 on page 8 shows the NFX150-C-S1, which is the compact model without an LTE support.

Figure 1: NFX150-C-S1



Figure 2 on page 8 shows the NFX150-C-S1-AA and NFX150-C-S1-AE devices. NFX150-C-S1-AA is a compact model with integrated LTE modem for Asia, Australia, and New Zealand. NFX150-C-S1-AE is a compact model with integrated LTE modem for Europe and North America.

Figure 2: NFX150-C-S1 with integrated LTE modem

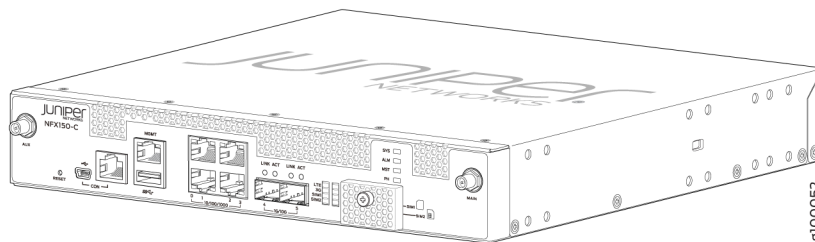

Figure 3 on page 8 shows the NFX150-S1, which is the rack-mount model.

Figure 3: NFX150-S1

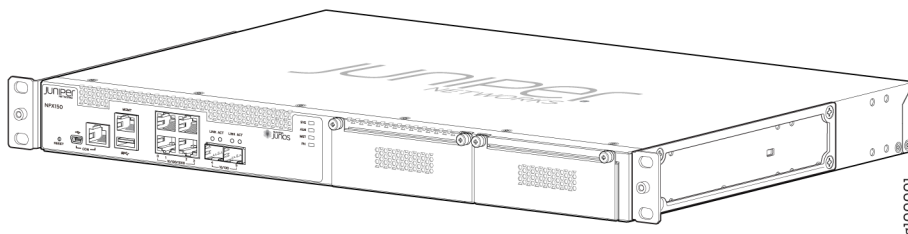
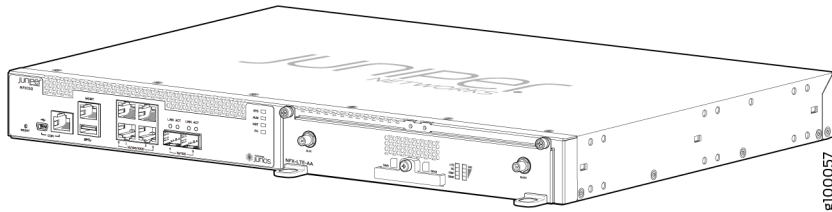

Figure 4 on page 9 shows the NFX150-S1 device with the LTE expansion module (NFX-LTE-AE and NFX-LTE-AA).

Figure 4: NFX150-S1 with the LTE expansion module



The LTE expansion module supports the following wireless standards:

- FCC Part 2
- FCC Part 22
- FCC Part 24, Part 27 and Part 90
- RSS 129 and RSS 133, RSS 130, RSS 199, and RSS 139
- RSS 132 and RSS 133
- EN 301 511 GSM
- EN 301 908-1
- EN 301 908-2
- The Certification and Engineering Bureau of Industry Canada (IC)
- Radio Equipment (RE) Directive of the European Union
- GCF
- CTIA-PTCRB

[Figure 5 on page 9](#) shows the NFX150-S1 device with the NFX-EM-6T2SFP expansion module.

Figure 5: NFX150-S1 with the NFX-EM-6T2SFP expansion module

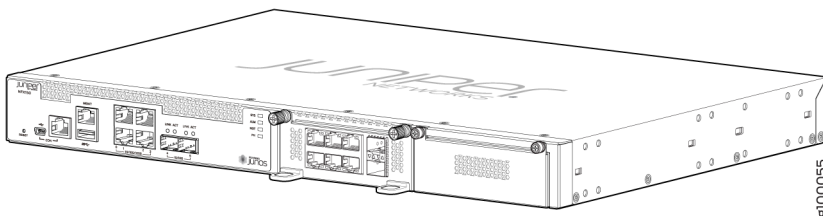

Benefits and Uses of NFX150

The NFX150 Network Services Platform provides these benefits:

- Highly scalable, supporting multiple Juniper and third-party VNFs on a single device. The modular software architecture provides high performance and scalability for routing, switching, and security enhanced by carrier-class reliability.
- Integrated security, routing, and switching functionality in a single control plane simplifies management and deployment.
- Supports a variety of flexible deployments. A distributed services deployment model ensures high availability, performance, and compliance. The NFX150 provides an open framework that supports industry standards, protocols, and seamless API integration.
- In addition to Ethernet connections, Wireless WAN support through the LTE expansion module provides more flexibility in deployments.
- Supports advanced security features such as IPsec connectivity, applications detection, and filtering for malicious traffic.
- The Secure Boot feature safeguards device credentials, automatically authenticates system integrity, verifies system configuration, and enhances overall platform security.
- Automated configuration eliminates complex device setup and delivers a plug-and-play experience.

NFX150 Chassis

IN THIS SECTION

- [Front Panel of an NFX150 Device | 10](#)
- [Rear Panel of an NFX150 Device | 16](#)
- [LED Details of an NFX150 Device | 20](#)

Front Panel of an NFX150 Device

[Figure 6 on page 11](#) shows the front panel components of an NFX150-C-S1 device.

Figure 6: Front Panel Components of NFX150-C-S1

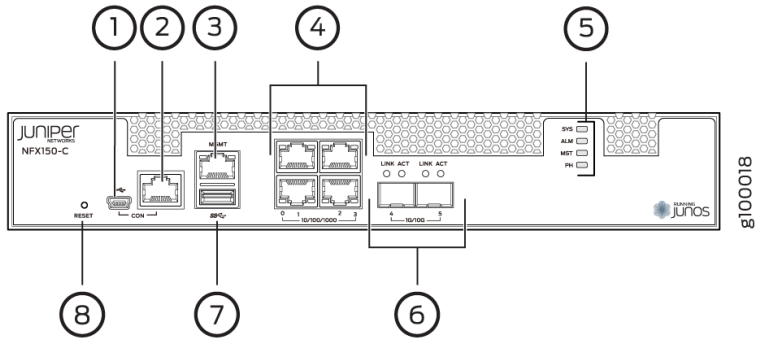

1– Mini-USB console port	5– System status LEDs
2– RJ-45 console port	6– Two 1-Gigabit Ethernet/10-Gigabit Ethernet SFP+ WAN ports
3– One 10/100/ 1000BASE-T RJ-45 management port	7– USB 3.0 port
4– Four 10/100/ 1000BASE-T RJ-45 LAN ports	8– Reset button

[Figure 7 on page 13](#) shows the front panel components of NFX150-C-S1-AA and NFX150-C-S1-AE devices.

Figure 7: Front Panel Components of NFX150-C-S1-AA and NFX150-C-S1-AE

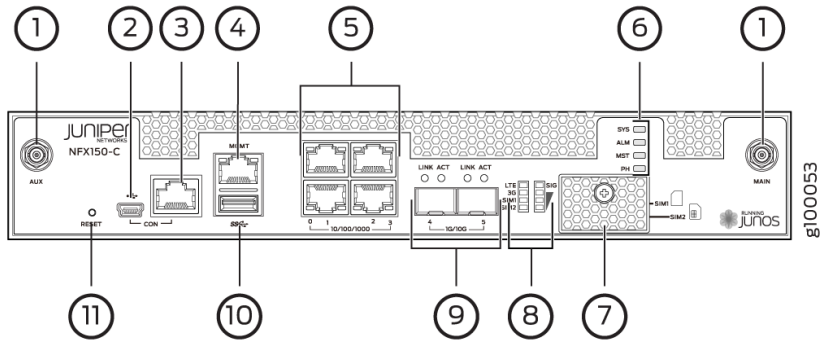

1– Antenna slot	7– SIM card cover
2– Mini USB console port	8– LTE modem LEDs
3– RJ-45 console port	9– Two 1-Gigabit Ethernet/10-Gigabit Ethernet SFP+ WAN ports
4– One 10/100/1000BASE-T RJ-45 management port	10– USB 3.0 port
5– Four 10/100/1000BASE-T RJ-45 LAN ports	11– Reset button
6– System status LEDs	

Figure 8 on page 15 shows the front panel components of an NFX150-S1 device.

Figure 8: Front Panel Components of NFX150-S1

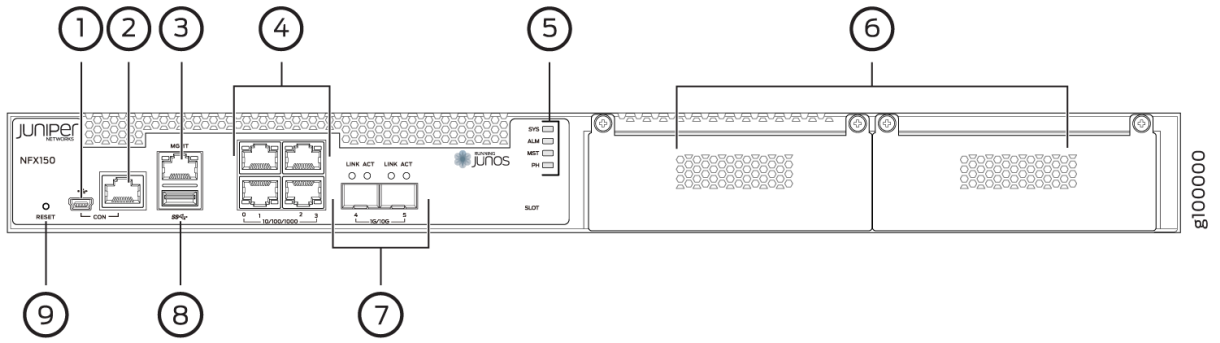

1– Mini USB console Port	6– Expansion module slots
2– RJ-45 console port	7– Two 1-Gigabit Ethernet/10-Gigabit Ethernet SFP+ WAN ports
3– One 10/100/1000BASE-T RJ-45 management port	8– USB 3.0 port
4– Four 10/100/1000BASE-T RJ-45 LAN ports	9– Reset button
5– System status LEDs	

Rear Panel of an NFX150 Device

[Figure 9 on page 17](#) shows the rear panel of the NFX150-C-S1 device. The rear panel of the NFX150-C-S1 device consists of the following components:

Figure 9: Rear Panel Components of NFX150-C-S1

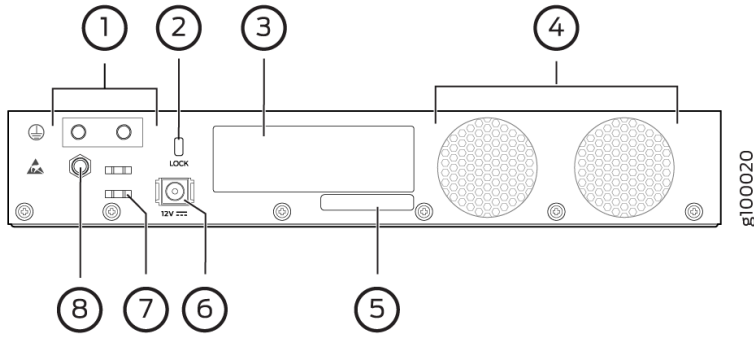

1– Grounding point	5– CLEI code
2– Lock	6– Power supply input
3– Serial number	7– Cable tie holder
4– Fans	8– Electrostatic discharge (ESD) point

[Figure 10 on page 19](#) shows the rear panel of the NFX150-S1 device. The rear panel of the NFX150-S1 device consists of the following components:

Figure 10: Rear Panel Components of NFX150-S1

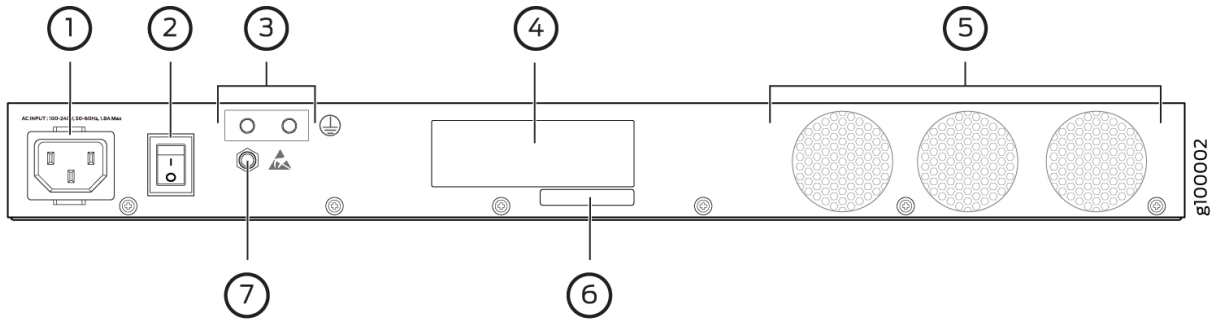

1– AC power cord inlet	5– Fans
2– Power switch	6– CLEI code
3– Grounding point	7– Electrostatic discharge (ESD) point
4– Serial number	

LED Details of an NFX150 Device

IN THIS SECTION

- Chassis Status LEDs | 20
- Network Port and Uplink Port LEDs | 22
- Management Port LEDs | 23
- LTE Module LEDs | 24

Chassis Status LEDs

The front panel of an NFX150-C-S1 and NFX150-S1 devices have chassis status LEDs labeled **ALM**, **SYS**, **MST** and **PH**.

Figure 6 shows the chassis status LEDs in an NFX150-C-S1 device.

Figure 11: Chassis Status LEDs in an NFX150-C-S1 Device

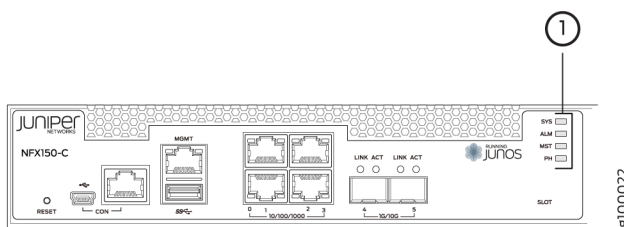

- | |
|---|
| 1– Chassis status LEDs (ALM , SYS , MST , and PH) |
|---|

Figure 7 shows the chassis status LEDs in an NFX150-S1 device.

Figure 12: Chassis Status LEDs in an NFX150-S1 Device

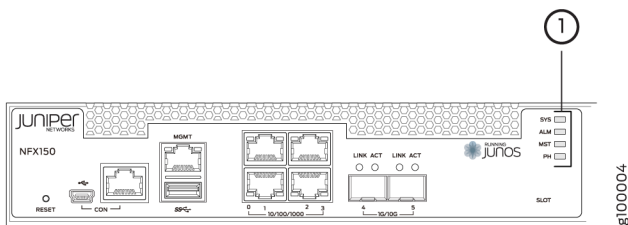

1– Chassis status LEDs (ALM, SYS, MST, and PH)

2– Slot

Table 1 describes the chassis status LEDs in an NFX150 device, their colors and states, and the status they indicate. You can view the colors of the four LEDs remotely through the CLI by issuing the operational mode command `show chassis led`.

Table 4: Chassis Status LEDs in an NFX150 Device

LED Label	Color	State and Description
ALM (Alarm)	Unlit	There is no alarm or the device is halted.
	Red	There is a major alarm.
	Amber	There is a minor alarm.
SYS (System)	Green	<ul style="list-style-type: none"> On steadily—Junos OS has been loaded on the device. Blinking—The device is booting. Off—The device is powered off or is halted.
MST (Primary)	Green	<ul style="list-style-type: none"> On steadily—The device is functioning normally. Off—The device is powered off or is halted.
PH	Unlit	There is no Network Service Activator transaction.

Table 4: Chassis Status LEDs in an NFX150 Device (Continued)

LED Label	Color	State and Description
	Green	<ul style="list-style-type: none"> On steadily—Network Service Activator transaction is successfully completed. That is, the Network Service Orchestrator in NFX150 contacted the Network Service Activator and provisioned the software image successfully. Blinking—Network Service Activator transaction is underway. Off—The device is powered off or is halted.
	Amber	<ul style="list-style-type: none"> On steadily—Network Service Activator transaction is terminated unsuccessfully. Blinking—Network Service Activator transaction is waiting for user input.

A major alarm (red) indicates a critical error condition that requires immediate action.

A minor alarm (amber) indicates a noncritical condition that requires monitoring or maintenance. A minor alarm left unchecked might cause interruption in service or performance degradation.

All four LEDs can be lit simultaneously.

Network Port and Uplink Port LEDs

Each network port and uplink port on the front panel of an NFX150 has two LEDs that indicate link activity and port status (see [Figure 13 on page 22](#)).

Figure 13: LEDs on the Network Port

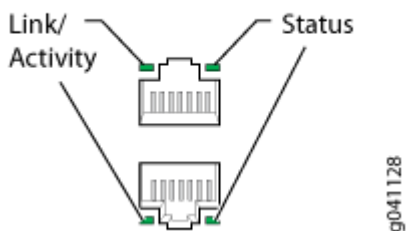

[Table 5 on page 23](#) describes the Link/Activity LED.

Table 5: Link/Activity LED on the Network Ports and Uplink Ports in NFX150 Devices

LED	Color	State and Description
Link/Activity	Green	<ul style="list-style-type: none"> • Blinking—The port and the link are active, and there is link activity. • On steadily—The port and the link are active, but there is no link activity. • Off—The port is not active.

Management Port LEDs

The management port on the front panel of an NFX150 device has two LEDs that indicate link activity and port status.

[Table 6 on page 23](#) describes the Link/Activity LED.

Table 6: Link/Activity LED on the Management Port of an NFX150 Device

LED	Color	State and Description
Link/Activity	Green	<ul style="list-style-type: none"> • Blinking—The port and the link are active, and there is link activity. • On steadily—The port and the link are active, but there is no link activity. • Off—The port is not active.

[Table 7 on page 24](#) describes the status LED.

Table 7: Status LED on the Management Port of an NFX150 Device

LED	Color	State and Description
Status	Green	Indicates the speed. The speed indicators are: <ul style="list-style-type: none"> • One blink per second—10 Mbps • Two blinks per second—100 Mbps • Three blinks per second—1000 Mbps

Table 8 on page 24 describes the slot LED.

Table 8: Slot LED of an NFX150 Device

LED	Color	State and Description
Slot	Green solid (On)	Module initial process is successful.
	Amber solid	Module initial process failed
	Off	Module is not present.

NOTE: If NFX-LTE-AA or NFX-LTE-AE module (two slot width expansion module) is inserted, the expansion module status is shown by Slot 0 LED.

LTE Module LEDs

Table 9 on page 24 lists the LEDs on the LTE module and their indications.

Table 9: LTE Module LED States

LED	Description
SIG (Received Signal Strength indicator)	Solid green (One bar) – Low signal strength. (≤ -99 dBm)

Table 9: LTE Module LED States (Continued)

LED	Description
	Solid green (Two bars) – Low signal strength. (From -98dBm to -87dBm)
	Solid green (Three bars) – Low signal strength. (From -86dBm to -76dBm)
	Solid green (Four bars) – High signal strength. (≥ -75 dBm)
	Unlit – No signal
3G	Solid green – 3G connection is established.
	Blinking green – Connection to a 3G network.
LTE	Solid green – LTE connection is established.
	Blinking green – Connection to a LTE network.
SIM1	Solid green – SIM1 is active.
SIM2	Solid green – SIM2 is active.

NOTE: If all the LEDs are blinking, it indicates that firmware updates are in progress. Do not power off the device before the updates complete.

RELATED DOCUMENTATION

[NFX150 Cooling System | 33](#)

[NFX150 Power System | 34](#)

NFX150 Interface Modules

IN THIS SECTION

- [LTE on NFX Devices | 26](#)
- [LTE Expansion Module \(NFX-LTE-AE and NFX-LTE-AA\) | 29](#)
- [NFX-EM-6T2SFP Expansion Module | 32](#)

LTE on NFX Devices

IN THIS SECTION

- [Overview | 26](#)
- [Features Supported on the LTE Module for NFX Devices | 27](#)
- [Understanding the LTE Physical Interface | 28](#)
- [Understanding the LTE Logical Interface | 28](#)

Overview

The LTE module operates on both 3G and 4G networks and provides wireless WAN support on the NFX150 devices. The NFX150 portfolio consists of models with or without LTE support. provides a summary of the models that support LTE.

Table 10: LTE Models

Model	Mode	Operating Region	Frequency Band
<ul style="list-style-type: none"> • NFX150-C-S1-AE • NFX150-C-S1E-AE • NFX-LTE-AE (expansion module supported on the NFX150-S1 and NFX150-S1E models) 	<ul style="list-style-type: none"> • LTE • HSPA+ 	<ul style="list-style-type: none"> • North America • European Union 	<p>For LTE:</p> <ul style="list-style-type: none"> • Bands 1 through 5, 7, 8, 12, 13, 20, 25, 26, 29, 30, and 41 <p>For 3G (HSPA+):</p> <ul style="list-style-type: none"> • Bands 1 through 5, and 8
<ul style="list-style-type: none"> • NFX150-C-S1-AA • NFX150-C-S1E-AA • NFX-LTE-AA (expansion module supported on the NFX150-S1 and NFX150-S1E models) 	<ul style="list-style-type: none"> • LTE • HSPA+ 	<ul style="list-style-type: none"> • Asia • Australia • New Zealand 	<p>For LTE:</p> <ul style="list-style-type: none"> • Bands 1,3, 5, 7, 8, 18, 19, 21, 28, 38, 39, 40, and 41 <p>For 3G (HSPA+):</p> <ul style="list-style-type: none"> • Bands 1, 5, 6, 8, 9, and 19

Features Supported on the LTE Module for NFX Devices

The LTE module supports the following features:

- Automatic switchover between service providers through dual SIMs—The module supports up to two Subscriber Identity Module (SIM) cards. Dual SIM cards allow connectivity to two different ISP networks and provide a failover mechanism when the current active network fails. Each SIM card is associated with a profile, which is used to connect to the network.
- Multiple service provider and access point name (APN) profiles—You can configure up to 16 profiles for each SIM, although only one profile can be active at a time. The LTE module supports two SIM cards and so you can configure a total of 32 profiles.
- LTE carrier aggregation—Carrier aggregation expands the LTE bandwidth by combining secondary bands, which results in increased capacity and network efficiency.
- SIM security functions—The module supports security functions such as SIM lock and unlock, and PIN change.
- Always-on, dial-on-demand, and backup modes—The Mini-PIM can be configured in three modes:
 - Always-on—The LTE module connects to the 3G/4G network after booting. The connection is always maintained, as long as there are no network or connectivity problems.

- Dial-on-demand—The Mini-PIM initiates a connection when it receives interesting traffic. You define interesting traffic using the dialer filter. To configure dial-on-demand using a dialer filter, you first configure the dialer filter and then apply the filter to the dialer interface.

NOTE: The dial-on-demand mode is supported only if the LTE module is configured as a primary interface.

- Backup—The module connects to the 3G/4G network when the primary connection fails.
- Primary and backup interface—You can configure the LTE module either as a primary interface or as a backup interface.

When configured as the primary interface, the LTE module supports both the Always-on and Dial-on-demand modes.

When configured as the backup interface, the LTE module connects to the network only when the primary interface fails.

- Over-the-air upgrade for modem firmware—Over-the-air (OTA) firmware upgrade enables automatic and timely upgrade of modem firmware when new firmware versions are available. The OTA upgrade can be enabled or disabled on the LTE module.

NOTE: OTA upgrade is disabled by default.

Understanding the LTE Physical Interface

The physical interface for the LTE module uses the name `cl-1/1/0`. You configure the following properties on the physical interface:

- A dialer pool to which the physical interface belongs and the priority of the interface in the pool.
- Profiles for the SIM cards.
- Radio access technology (automatic, 3G, LTE)

Understanding the LTE Logical Interface

The dialer interface, `dl0`, is a logical interface, which is used to trigger calls. When traffic is sent to the `dl0` interface, it enables the physical interface in the dialer pool and places calls through the physical interface. The dialer interface can perform backup and dialer filter functions. You can configure the dialer interface to operate in any one of the following ways:

- Primary interface—The dialer interface connects to the network and is always on.

- Backup interface for the primary WAN connection—The dialer interface is activated only when the primary connection fails.
- Dial-on-demand—The dialer interface activates the connection to the wireless network only when it receives interesting traffic.

The following rules apply when you configure dialer interfaces:

- You cannot configure the dialer interface as a constituent link in a multilink bundle.
- You cannot configure any dial-in options for the dialer interface.

You configure the following for a dialer interface:

- A dialer pool to which the physical interface belongs.
- Dial string (destination number to be dialed).

You can also specify optional operating parameters for the dialer interface:

- Activation delay—Number of seconds after the primary interface is down before the backup interface is activated. The default value is 0 seconds, and the maximum value is 60 seconds.
- Deactivation delay—Number of seconds after the primary interface is up before the backup interface is deactivated. The default value is 0 seconds, and the maximum value is 60 seconds.

LTE Expansion Module (NFX-LTE-AE and NFX-LTE-AA)

Figure 14 on page 29 shows the front panel components of the LTE expansion module.

Figure 14: Front Panel Components of the NFX-LTE-AE and NFX-LTE-AA

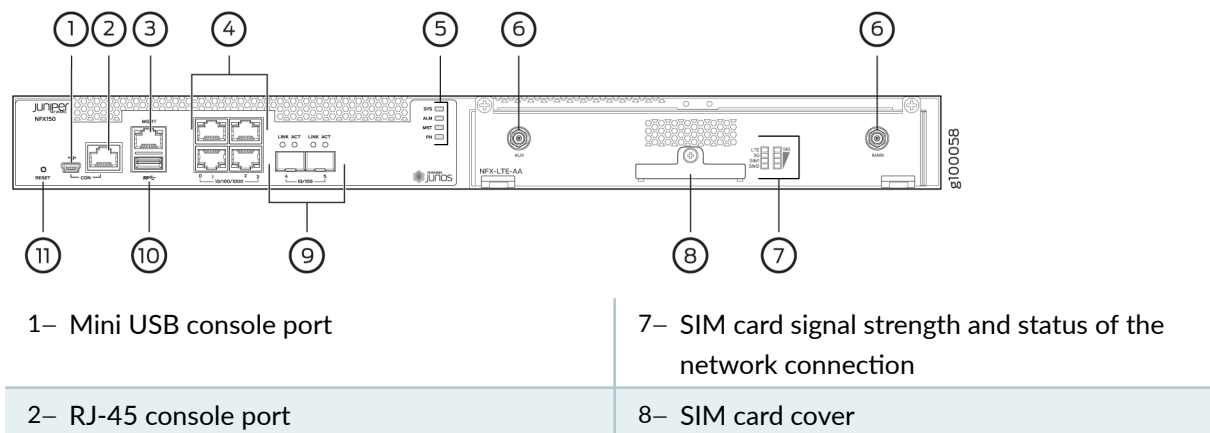

3– One 10/100/1000BASE-T RJ-45 management port	9– Two 1-Gigabit Ethernet/10-Gigabit Ethernet SFP+ WAN ports
4– Four 10/100/1000BASE-T RJ-45 LAN ports	10– USB 3.0 port
5– System status LEDs	11– Reset button
6– Antenna slot	

[Table 11 on page 30](#) lists the components on the front panel of the LTE expansion module.

Table 11: LTE Expansion Module Front Panel Components

Component	Description
Antenna connectors	Two SubMiniature version A (SMA) connectors.
SIM slots	Two slots, SIM1 and SIM2 , for inserting the SIM cards. The LTE Mini-PIM supports standard, micro, and nano SIMs. The standard SIM can be inserted directly in the SIM slot. To insert micro and nano SIMs, use the SIM adapters supplied with the Mini-PIM. The Mini-PIM is shipped with two SIM adapters.
LEDs	Indicate the status at a glance.

The LTE expansion module supports two multi-band swivel-mount dipole antennas, which can be rotated 360°. You can rotate the antennas and select the angle at which the signal strength is high. [Table 12 on page 30](#) lists the specifications for the antenna.

Table 12: Specifications for the LTE Expansion Module Antenna

Specification	Value
Part number	640-077768
Operating frequency range	<ul style="list-style-type: none"> • 700~960 MHz • 1575~2700 MHz
Voltage Standing Wave Ratio (VSWR)	<=2.8
Impedance	50 Ohms

Table 12: Specifications for the LTE Expansion Module Antenna (Continued)

Specification	Value
Radiation	Omnidirectional
Gain	1-4 dBi
Polarization	Vertical
Connector type	SMA
Length	120 mm

The antenna is connected to the NFX150 device through the magnetic antenna base. [Table 13 on page 31](#) lists the specifications for the antenna base.

Table 13: Antenna Base Specifications

Specification	Value
Part number	640-077767
Cable length	3 m
Connector type	SMA
Dimensions (H x W x L)	29.50 mm x 73 mm x 73 mm

[Table 14 on page 31](#) provides the hardware specifications for the LTE expansion module.

Table 14: LTE Expansion module Hardware Specifications

Description	Value
Dimensions (W x D x H)	8.40 in x 5.20 in x 1.45 in

Table 14: LTE Expansion module Hardware Specifications (Continued)

Description	Value
Weight	368 grams
Connector Type	Golden Finger
Environmental Operating Temperature	32° to 104° F (0° to 40° C)
Storage Temperature	- 40°F to 158° F (-40° to 70° C)
Relative Humidity	(Operating) 5 to 90% non-condensing

NFX-EM-6T2SFP Expansion Module

Figure 15 on page 32 shows the front panel components of NFX-EM-6T2SFP.

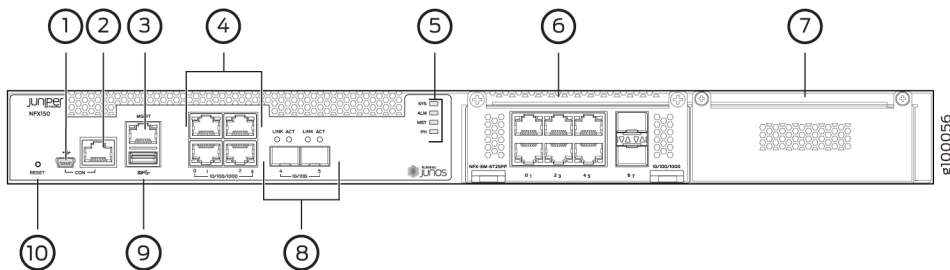
Figure 15: Front Panel Components of the NFX-EM-6T2SFP

1– Mini USB console port	6– 6T2SFP interface module
2– RJ-45 console port	7– Blank panel
3– One 10/100/1000BASE-T RJ-45 management port	8– Two 1-Gigabit Ethernet/10-Gigabit Ethernet SFP+ WAN ports
4– Four 10/100/1000BASE-T RJ-45 LAN ports	9– USB 3.0 port
5– System status LEDs	10– Reset button

Table 15 on page 33 provides the hardware specifications for the NFX-EM-6T2SFP expansion module.

Table 15: Hardware Specifications for NFX-EM-6T2SFP

Description	Value
Dimensions (W x D x H)	4.20 in x 5.20 in x 1.45 in
Weight	242 gms
Connector Type	Golden Finger
Environmental Operating Temperature	32° to 104° F (0° to 40° C)
Storage Temperature	- 40°F to 158° F (-40° to 70° C)
Relative Humidity	(Operating) 5 to 90% non-condensing

RELATED DOCUMENTATION

[NFX150 Network Cable and Transceiver Planning | 52](#)

[NFX150 Cable Specifications and Pinouts | 60](#)

NFX150 Cooling System

The NFX150 devices have front-to-back airflow. The air intake to cool the chassis is located on the front of the chassis. Air is pulled into the chassis and pushed toward the fans, which are built-in. Hot air exhausts from the rear of the chassis. See [Figure 16 on page 34](#).

Figure 16: Front-to-Back Airflow Through the NFX150 Chassis

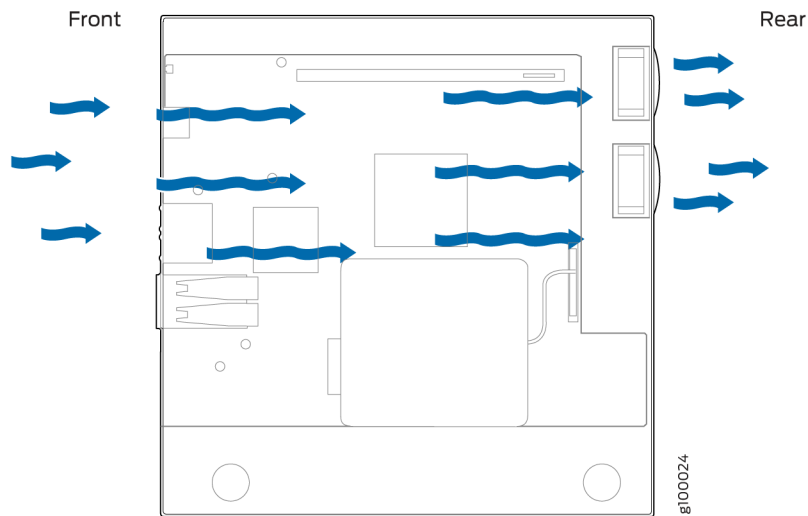

RELATED DOCUMENTATION

Prevention of Electrostatic Discharge Damage

NFX150 Power System

IN THIS SECTION

- [Power Supply in NFX150 Devices | 35](#)
- [AC Power Supply Specifications for an NFX150 Device | 35](#)
- [AC Power Cord Specifications for an NFX150 Device | 35](#)

Power Supply in NFX150 Devices

NFX150 devices use a fixed, internal AC power supply. The power supply distributes different output voltages to the device components according to their voltage requirements. The power supply is fixed in the chassis and is not field-replaceable.

The power supply has a single AC appliance inlet that requires a dedicated AC power feed. The AC power cord inlet is on the rear panel of the device.

AC Power Supply Specifications for an NFX150 Device

Table 16 on page 35 describes the AC power specifications for an NFX150 device.

Table 16: AC Power Specifications for an NFX150 Device

Product SKU	AC Input Voltage (Operating Range)	AC Input Line Frequency	AC Input Current Rating	Maximum Power Consumption	Power Supply Type
NFX150-S1	100 through 240 VAC	50–60 Hz nominal	1.8 A at 240 VAC	150 W	Internal
NFX150-S1E	100 through 240 VAC	50–60 Hz nominal	1.8 A at 240 VAC	150 W	Internal

SEE ALSO

[General Safety Guidelines and Warnings | 139](#)

[General Electrical Safety Guidelines and Warnings | 163](#)

AC Power Cord Specifications for an NFX150 Device

A detachable AC power cord is supplied with the AC power supplies. The coupler is type C13 as described by International Electrotechnical Commission (IEC) standard 60320. The plug at the male end of the power cord fits into the power source outlet that is standard for your geographical location.



CAUTION: The AC power cord provided with each power supply is intended for use with that power supply only and not for any other use.

NOTE: In North America, AC power cords must not exceed 4.5 meters in length, to comply with National Electrical Code (NEC) Sections 400-8 (NFPA 75, 5-2.2) and 210-52 and Canadian Electrical Code (CEC) Section 4-010(3). The cords supplied with the switch are in compliance.

Table 17 on page 36 gives the AC power cord specifications for the countries and regions listed in the table.

Table 17: AC Power Cord Specifications

Country/Region	Electrical Specifications	Plug Standards	Juniper Model Number
Argentina	250 VAC, 10 A, 50 Hz	IRAM 2073 Type RA/3	CBL-EX-PWR-C13-AR
Australia	250 VAC, 10 A, 50 Hz	AS/NZZS 3112 Type SAA/3	CBL-EX-PWR-C13-AU
Brazil	250 VAC, 10 A, 50 Hz	NBR 14136 Type BR/3	CBL-EX-PWR-C13-BR
China	250 VAC, 10 A, 50 Hz	GB 1002-1996 Type PRC/3	CBL-EX-PWR-C13-CH
Europe (except Italy, Switzerland, and United Kingdom)	250 VAC, 10 A, 50 Hz	CEE (7) VII Type VIIG	CBL-EX-PWR-C13-EU
India	250 VAC, 10 A, 50 Hz	IS 1293 Type IND/3	CBL-EX-PWR-C13-IN
Israel	250 VAC, 10 A, 50 Hz	SI 32/1971 Type IL/3G	CBL-EX-PWR-C13-IL
Italy	250 VAC, 10 A, 50 Hz	CEI 23-16 Type I/3G	CBL-EX-PWR-C13-IT

Table 17: AC Power Cord Specifications (Continued)

Country/Region	Electrical Specifications	Plug Standards	Juniper Model Number
Japan	125 VAC, 12 A, 50 Hz or 60 Hz	SS-00259 Type VCTF	CBL-EX-PWR-C13-JP
Korea	250 VAC, 10 A, 50 Hz or 60 Hz	CEE (7) VII Type VIIGK	CBL-EX-PWR-C13-KR
North America	125 VAC, 13 A, 60 Hz	NEMA 5-15 Type N5-15	CBL-EX-PWR-C13-US
South Africa	250 VAC, 10 A, 50 Hz	SABS 164/1:1992 Type ZA/13	CBL-EX-PWR-C13-SA
Switzerland	250 VAC, 10 A, 50 Hz	SEV 6534-2 Type 12G	CBL-EX-PWR-C13-SZ
Taiwan	125 VAC, 11 A and 15 A, 50 Hz	NEMA 5-15P Type N5-15P	CBL-EX-PWR-C13-TW
United Kingdom	250 VAC, 10 A, 50 Hz	BS 1363/A Type BS89/13	CBL-EX-PWR-C13-UK

Figure 17 on page 37 illustrates the plug on the power cord for some of the countries or regions listed in Table 17 on page 36.

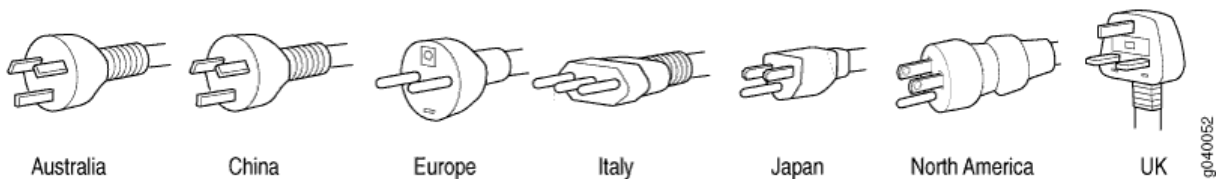
Figure 17: AC Plug Types**SEE ALSO**

[General Safety Guidelines and Warnings | 139](#)

[General Electrical Safety Guidelines and Warnings | 163](#)

2

CHAPTER

Site Planning, Preparation, and Specifications

Site Preparation Checklist for NFX150 Devices | 40

NFX150 Site Guidelines and Requirements | 42

NFX150 Network Cable and Transceiver Planning | 52

NFX150 Cable Specifications and Pinouts | 60

Site Preparation Checklist for NFX150 Devices

The checklist in [Table 18 on page 40](#) summarizes the tasks you need to perform when preparing a site for NFX150 devices installation.

Table 18: Site Preparation Checklist

Item or Task	For More Information	Performed by	Date
Environment			
Verify that environmental factors such as temperature and humidity do not exceed device tolerances.	"Environmental Requirements and Specifications for an NFX150 Device" on page 44		
Power			
Measure distance between external power sources and device installation site.			
Locate sites for connection of system grounding.			
Calculate the power consumption and requirements.	"AC Power Supply Specifications for an NFX150 Device" on page 35		
Hardware Configuration			
Choose the number and types of devices you want to install.	"NFX150 Network Services Platform Overview" on page 2		
Rack or Cabinet			
Verify that your rack or cabinet meets the minimum requirements for the installation of the device.	"Rack Requirements for NFX150 Devices" on page 49 "Cabinet Requirements for an NFX150 Device" on page 51		

Table 18: Site Preparation Checklist (Continued)

Item or Task	For More Information	Performed by	Date
Plan rack or cabinet location, including required space clearances.	"Clearance Requirements for Airflow and Hardware Maintenance for an NFX150 Device" on page 46		
Secure the rack or cabinet to the floor and building structure.			
Desk			
Verify that the desk meets the minimum requirements for the installation of the device.	"Requirements for Mounting an NFX150 Device on a Desktop or Other Level Surface" on page 49		
Verify that there is appropriate clearance in your selected location.	"Clearance Requirements for Airflow and Hardware Maintenance for an NFX150 Device" on page 46		
Wall			
Verify that the wall meets the minimum requirements for the installation of the NFX150 device.	"Requirements for Mounting an NFX150 Device on a Wall" on page 49		
Verify that there is appropriate clearance in your selected location.	"Clearance Requirements for Airflow and Hardware Maintenance for an NFX150 Device" on page 46		
Cables			

Table 18: Site Preparation Checklist (Continued)

Item or Task	For More Information	Performed by	Date
Acquire cables and connectors: <ul style="list-style-type: none"> • Determine the number of cables needed based on your planned configuration. • Review the maximum distance allowed for each cable. Choose the length of cable based on the distance between the hardware components being connected. 			
Plan the cable routing and management.			

RELATED DOCUMENTATION

General Safety Guidelines and Warnings

General Site Guidelines

[NFX150 Installation Overview | 69](#)

[Mounting an NFX150 Device | 73](#)

NFX150 Site Guidelines and Requirements

IN THIS SECTION

- [General Site Guidelines | 43](#)
- [Chassis Physical Specifications for an NFX150 Device | 43](#)
- [Environmental Requirements and Specifications for an NFX150 Device | 44](#)
- [Site Electrical Wiring Guidelines | 45](#)
- [Clearance Requirements for Airflow and Hardware Maintenance for an NFX150 Device | 46](#)

- Requirements for Mounting an NFX150 Device on a Desktop or Other Level Surface | 49
- Requirements for Mounting an NFX150 Device on a Wall | 49
- Rack Requirements for NFX150 Devices | 49
- Cabinet Requirements for an NFX150 Device | 51

General Site Guidelines

Efficient device operation requires proper site planning and maintenance. It also requires proper layout of the equipment, rack or cabinet, and wiring closet.

To plan and create an acceptable operating environment for your device and prevent environmentally caused equipment failures:

- Keep the area around the chassis free from dust and conductive material, such as metal flakes.
- Follow the prescribed airflow guidelines to ensure that the cooling system functions properly. Ensure that exhaust from other equipment does not blow into the intake vents of the device.
- Follow the prescribed electrostatic discharge (ESD) prevention procedures to prevent damaging the equipment. Static discharge can cause components to fail completely or intermittently over time.
- Install the device in a secure area, so that only authorized personnel can access the device.

Chassis Physical Specifications for an NFX150 Device

NFX150 device chassis is a rigid sheet-metal structure that houses the hardware components. [Table 19 on page 43](#) summarizes the physical specifications of the NFX150 chassis.

Table 19: Physical Specifications for the NFX150 Device Chassis

Product SKU	Height	Width	Depth	Weight
NFX150-C-S1	1.72 in. (4.37 cm)	10.66 in. (27.1 cm)	11.17 in. (28.38 cm)	8.6 lb (3.9 kg)
NFX150-C-S1-AA	1.72 in. (4.37 cm)	10.66 in. (27.1 cm)	11.17 in. (28.38 cm)	8.6 lb (3.9 kg)

Table 19: Physical Specifications for the NFX150 Device Chassis (Continued)

Product SKU	Height	Width	Depth	Weight
NFX150-C-S1-AE	1.72 in. (4.37 cm)	10.66 in. (27.1 cm)	11.17 in. (28.38 cm)	8.6 lb (3.9 kg)
NFX150-C-S1E-AA	1.72 in. (4.37 cm)	10.66 in. (27.1 cm)	11.17 in. (28.38 cm)	8.6 lb (3.9 kg)
NFX150-C-S1E-AE	1.72 in. (4.37 cm)	10.66 in. (27.1 cm)	11.17 in. (28.38 cm)	8.6 lb (3.9 kg)
NFX150-S1	1.72 in. (4.37 cm)	17.36 in. (44.1 cm)	12 in. (30.5 cm)	11.68 lb (5.3 kg)
NFX150-S1E	1.72 in. (4.37 cm)	17.36 in. (44.1 cm)	15.50 in. (39.4 cm)	11.68 lb (5.3 kg)

Environmental Requirements and Specifications for an NFX150 Device

The device must be installed in a rack or cabinet. It must be housed in a dry, clean, well-ventilated, and temperature-controlled environment.

Follow these environmental guidelines:

- The site must be as dust-free as possible, because dust can clog air intake vents and filters, reducing the efficiency of the device cooling system.
- Maintain ambient airflow for normal operation of the device. If the airflow is blocked or restricted, or if the intake air is too warm, the device might overheat, leading to the device temperature monitor shutting down the device to protect the hardware components.

[Table 20 on page 44](#) provides the required environmental conditions for normal operation of the device.

Table 20: NFX150 Device Environmental Tolerances

Description	Tolerance
Altitude	No performance degradation up to 6500 feet (1828 meters) at 96° F (40° C)

Table 20: NFX150 Device Environmental Tolerances (*Continued*)

Description	Tolerance
Relative humidity	Normal operation ensured in relative humidity range of 5% through 90%, noncondensing
Temperature	Normal operation ensured in temperature range of 32° F through 122° F (0° C through 40° C)
Seismic	Complies with Zone 4 earthquake requirements as per GR-63, Issue 4

SEE ALSO

| [NFX150 Installation Overview](#) | 69

Site Electrical Wiring Guidelines

Table 21 on page 46 describes the factors you must consider while planning the electrical wiring at your site.



WARNING: You must provide a properly grounded and shielded environment and use electrical surge-suppression devices.

Avertissement Vous devez établir un environnement protégé et convenablement mis à la terre et utiliser des dispositifs de parasurtension.

Table 21: Site Electrical Wiring Guidelines

Site Wiring Factor	Guidelines
Signaling limitations	<p>If your site experiences any of the following problems, consult experts in electrical surge suppression and shielding:</p> <ul style="list-style-type: none"> • Improperly installed wires cause radio frequency interference (RFI). • Damage from lightning strikes occurs when wires exceed recommended distances or pass between buildings. • Electromagnetic pulses (EMPs) caused by lightning damage unshielded conductors and electronic devices.
Radio frequency interference	<p>To reduce or eliminate RFI from your site wiring, do the following:</p> <ul style="list-style-type: none"> • Use a twisted-pair cable with a good distribution of grounding conductors. • If you must exceed the recommended distances, use a high-quality twisted-pair cable with one ground conductor for each data signal, when applicable.
Electromagnetic compatibility	<p>If your site is susceptible to problems with electromagnetic compatibility (EMC), particularly from lightning or radio transmitters, seek expert advice.</p> <p>Strong sources of electromagnetic interference (EMI) can cause:</p> <ul style="list-style-type: none"> • Destruction of the signal drivers and receivers in the device • Electrical hazards as a result of power surges conducted over the lines into the equipment.

Clearance Requirements for Airflow and Hardware Maintenance for an NFX150 Device

When planning the site for installing an NFX150 device, you must allow sufficient clearance around the installed chassis (see [Figure 18 on page 47](#) and [Figure 19 on page 48](#)).

Figure 18: Clearance Requirements for Airflow and Hardware Maintenance for an NFX150-S1 Device

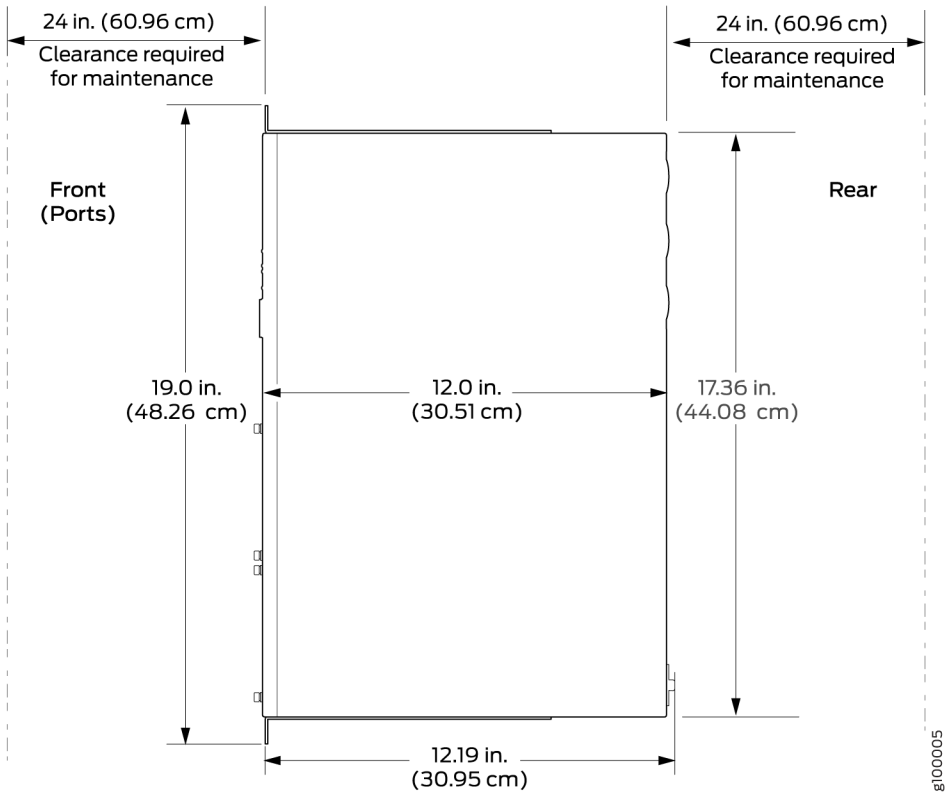
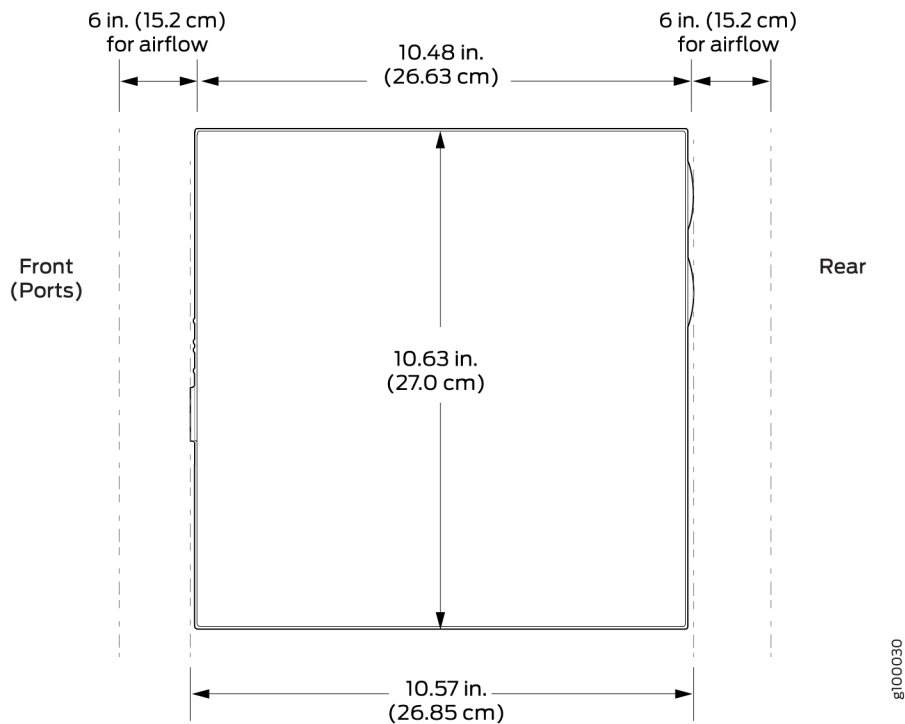

Figure 19: Clearance Requirements for Airflow and Hardware Maintenance for Wall Mounting an NFX150-C-S1 Device



- For the cooling system to function properly, the airflow around the chassis must be unrestricted. See ["NFX150 Cooling System" on page 33](#) for more information about the airflow through the chassis.
- If you are mounting an NFX150 device in a rack or cabinet with other equipment, ensure that the exhaust from other equipment does not blow into the intake vents of the chassis.
- Leave at least 24 in. (61 cm) both in front of and behind the NFX150 device. For service personnel to remove and install hardware components, you must leave adequate space at the front and back of the NFX150. NEBS GR-63 recommends that you allow at least 30 in. (76.2 cm) in front of the rack or cabinet and 24 in. (61 cm) behind the rack or cabinet.

SEE ALSO

[Rack-Mounting and Cabinet-Mounting Warnings | 147](#)

Requirements for Mounting an NFX150 Device on a Desktop or Other Level Surface

You can install NFX150 device on a desktop or other such level surface, by attaching the four rubber feet (provided) to the bottom of the chassis.

When choosing a location, allow at least 6 in. (15.2 cm) of clearance between the front and back of the chassis and adjacent equipment or walls.

Ensure that the desktop or other level surface on which the device is installed is stable and securely supported.

Requirements for Mounting an NFX150 Device on a Wall

You can install the NFX150 device on a wall. When choosing a location, allow at least 6 in. (15.2 cm) of clearance between the front and back of the chassis and adjacent equipment or walls.

Ensure that the wall onto which the device is installed is stable and securely supported.

If you are mounting the device in sheetrock (wall board with a gypsum plaster core) or in wall board not backed by wall studs, use hollow wall anchors capable of supporting the combined weight of two fully loaded chassis. Insert the screws into wall studs wherever possible to provide added support for the chassis.

Use the wall-mount kit from Juniper Networks to mount the device on a wall. The wall-mount kit is not part of the standard package and must be ordered separately.

Rack Requirements for NFX150 Devices

You can mount the NFX150 devices on two-post racks or four-post racks.

Rack requirements consist of:

- Rack type
- Mounting bracket hole spacing
- Rack size and strength
- Rack connection to the building structure

[Table 22 on page 50](#) provides the rack requirements and specifications for the device.

Table 22: Rack Requirements and Specifications for the Device

Rack Requirement	Guidelines
Rack type	<p>Use a two-post rack or a four-post rack. You can mount the device on any two-post or four-post rack that provides bracket holes or hole patterns spaced at 1 U (1.75 in. or 4.45 cm) increments and that meets the size and strength requirements to support the weight.</p> <p>A U is the standard rack unit defined in <i>Cabinets, Racks, Panels, and Associated Equipment</i> (document number EIA-310-D) published by the Electronics Industry Association (http://www.ecianow.org/standards-practices/standards/).</p> <p>The rack must meet the strength requirements to support the weight of the chassis.</p>
Mounting bracket hole spacing	<p>The holes in the mounting brackets are spaced at 1 U (1.75 in. or 4.45 cm), so that the device can be mounted in any rack that provides holes spaced at that distance.</p>
Rack size and strength	<ul style="list-style-type: none"> • Ensure that the rack complies with the standard defined for 19-in. rack as defined in <i>Cabinets, Racks, Panels, and Associated Equipment</i> (document number EIA-310-D) published by the Electronics Industry Association (http://www.ecianow.org/standards-practices/standards/). • Ensure that the rack rails are spaced widely enough to accommodate the device chassis' external dimensions of 1.72 in. (4.3 cm) height, 17.36 in. (44.1 cm) width, and 12 in. (30.5 cm) depth. The 19-in. rack brackets dimensions are 0.82 in. (2.1 cm) wide, 1.72 in. (4.3 cm) height, and 2.1 in. (5.4 cm) depth. The 23-in. rack brackets dimensions are 3.3 in. (8.4 cm) wide, 1.72 in. (4.3 cm) height, and 8.5 in. (21.6 cm) depth. • The rack must be strong enough to support the weight of the device. • Ensure that the spacing of rails and adjacent racks allows for the proper clearance around the device and rack.
Rack connection to building structure	<ul style="list-style-type: none"> • Secure the rack to the building structure. • If earthquakes are a possibility in your geographical area, secure the rack to the floor. • Secure the rack to the ceiling brackets as well as wall or floor brackets for maximum stability.

One pair of mounting brackets for mounting the device on two posts of a rack is supplied with each device. For mounting the device on four posts of a rack or cabinet, you can order a four-post rack-mount kit separately.

SEE ALSO

[NFX150 Chassis | 10](#)

[Rack-Mounting and Cabinet-Mounting Warnings | 147](#)

Cabinet Requirements for an NFX150 Device

You can mount the NFX150 device in an enclosure or cabinet that contains a four-post 19-in. open rack as defined in *Cabinets, Racks, Panels, and Associated Equipment* (document number EIA-310-D) published by the Electronics Industry Association.

Cabinet requirements consist of:

- Cabinet size and clearance
- Cabinet airflow requirements

[Table 23 on page 51](#) provides the cabinet requirements and specifications for the NFX150 device.

Table 23: Cabinet Requirements for the NFX150 Device

Cabinet Requirement	Guidelines
Cabinet size and clearance	The minimum cabinet size for accommodating an NFX150 device is 36 in. (91.4 cm) deep. Large cabinets improve airflow and reduce the chance of overheating.

Table 23: Cabinet Requirements for the NFX150 Device *(Continued)*

Cabinet Requirement	Guidelines
Cabinet airflow requirements	<p>When you mount the NFX150 device in a cabinet, ensure that ventilation through the cabinet is sufficient to prevent overheating.</p> <ul style="list-style-type: none"> • Ensure that the cool air supply you provide through the cabinet adequately dissipates the thermal output of the NFX150 device. • Ensure that the cabinet allows the chassis hot exhaust air to exit the cabinet without recirculating into the NFX150 device. An open cabinet (without a top or doors) that employs hot air exhaust extraction from the top allows the best airflow through the chassis. If the cabinet contains a top or doors, perforations in these elements assist with removing the hot air exhaust. • Install the NFX150 device in the cabinet in a way that maximizes the open space on the side of the chassis that has the hot air exhaust. • Route and dress all cables to minimize the blockage of airflow to and from the chassis. • Ensure that the spacing of rails and adjacent cabinets allows for the proper clearance around the NFX150 device and cabinet. • A cabinet larger than the minimum required provides better airflow and reduces the chance of overheating.

RELATED DOCUMENTATION

[NFX150 Installation Overview | 69](#)

NFX150 Network Cable and Transceiver Planning

IN THIS SECTION

● [Pluggable Transceivers Supported on NFX150 Devices | 53](#)

- SFP+ Direct Attach Cables for NFX150 Devices | 54
- Understanding NFX150 Devices Fiber-Optic Cable Signal Loss, Attenuation, and Dispersion | 55
- Calculating the Fiber-Optic Cable Power Budget for an NFX150 Device | 57
- Calculating the Fiber-Optic Cable Power Margin for an NFX150 Device | 58

Pluggable Transceivers Supported on NFX150 Devices

Uplink module ports on NFX150 devices support SFP and SFP+ transceivers.

NOTE: We recommend that you use only optical transceivers and optical connectors purchased from Juniper Networks with your Juniper Networks device.



CAUTION: The Juniper Networks Technical Assistance Center (JTAC) provides complete support for Juniper-supplied optical modules and cables. However, JTAC does not provide support for third-party optical modules and cables that are not qualified or supplied by Juniper Networks. If you face a problem running a Juniper device that uses third-party optical modules or cables, JTAC may help you diagnose host-related issues if the observed issue is not, in the opinion of JTAC, related to the use of the third-party optical modules or cables. Your JTAC engineer will likely request that you check the third-party optical module or cable and, if required, replace it with an equivalent Juniper-qualified component.

Use of third-party optical modules with high-power consumption (for example, coherent ZR or ZR+) can potentially cause thermal damage to or reduce the lifespan of the host equipment. Any damage to the host equipment due to the use of third-party optical modules or cables is the users' responsibility. Juniper Networks will accept no liability for any damage caused due to such use.

For the list of supported transceivers and its specifications, see the [Hardware Compatibility Tool](#).

SEE ALSO

| [NFX150 Chassis](#) | 10

SFP+ Direct Attach Cables for NFX150 Devices

IN THIS SECTION

- [Cable Specifications | 54](#)
- [Standards Supported by DAC Cables | 55](#)

Small form-factor pluggable plus transceiver (SFP+) direct attach copper (DAC) cables, also known as Twinax cables, are suitable for in-rack connections between servers and switches. They are suitable for short distances of up to 23 ft (7 m), making them ideal for highly cost-effective networking connectivity within a rack and between adjacent racks.

This topic describes:

Cable Specifications

NFX150 devices support SFP+ passive DAC cables. The passive Twinax cable is a straight cable with no active electronic components. NFX150 devices support 1 m, 3 m, and 5 m long SFP+ passive DAC cables.

NOTE: We recommend that you use only SFP+ DAC cables purchased from Juniper Networks with your Juniper Networks device.



CAUTION: The Juniper Networks Technical Assistance Center (JTAC) provides complete support for Juniper-supplied optical modules and cables. However, JTAC does not provide support for third-party optical modules and cables that are not qualified or supplied by Juniper Networks. If you face a problem running a Juniper device that uses third-party optical modules or cables, JTAC may help you diagnose host-related issues if the observed issue is not, in the opinion of JTAC, related to the use of the third-party optical modules or cables. Your JTAC engineer will likely request that you check the third-party optical module or cable and, if required, replace it with an equivalent Juniper-qualified component.

Use of third-party optical modules with high-power consumption (for example, coherent ZR or ZR+) can potentially cause thermal damage to or reduce the lifespan of

the host equipment. Any damage to the host equipment due to the use of third-party optical modules or cables is the users' responsibility. Juniper Networks will accept no liability for any damage caused due to such use.

The cables are hot-removable and hot-insertable: You can remove and replace them without powering off the switch or disrupting switch functions. A cable comprises a low-voltage cable assembly that connects directly into two SFP+ ports, one at each end of the cable. The cables use high-performance integrated duplex serial data links for bidirectional communication and are designed for data rates of up to 10 Gbps.

For the list of supported DAC cables and its specifications, see the [Hardware Compatibility Tool](#).

Standards Supported by DAC Cables

The cables comply with the following standards:

- SFP mechanical standard SFF-843—see <ftp://ftp.seagate.com/sff/SFF-8431.PDF> .
- Electrical interface standard SFF-8432—see <ftp://ftp.seagate.com/sff/SFF-8432.PDF> .
- SFP+ Multi-Source Alliance (MSA) standards

SEE ALSO

[Pluggable Transceivers Supported on NFX150 Devices | 53](#)

[Installing a Transceiver in an NFX150 Device | 94](#)

[Removing a Transceiver from an NFX150 Device | 118](#)

Understanding NFX150 Devices Fiber-Optic Cable Signal Loss, Attenuation, and Dispersion

IN THIS SECTION

- [Signal Loss in Multimode and Single-Mode Fiber-Optic Cables | 56](#)
- [Attenuation and Dispersion in Fiber-Optic Cable | 56](#)

To determine the power budget and power margin needed for fiber-optic connections, you need to understand how signal loss, attenuation, and dispersion affect transmission. The NFX150 devices use various types of network cable, including multimode and single-mode fiber-optic cables.

Signal Loss in Multimode and Single-Mode Fiber-Optic Cables

Multimode fiber is large enough in diameter to allow rays of light to reflect internally (bounce off the walls of the fiber). Interfaces with multimode optics typically use LEDs as light sources. However, LEDs are not coherent light sources. They spray varying wavelengths of light into the multimode fiber, which reflects the light at different angles. Light rays travel in jagged lines through a multimode fiber, causing signal dispersion. When light traveling in the fiber core radiates into the fiber cladding (layers of lower refractive index material in close contact with a core material of higher refractive index), higher-order mode loss occurs. Together, these factors reduce the transmission distance of multimode fiber compared to that of single-mode fiber.

Single-mode fiber is so small in diameter that rays of light reflect internally through one layer only. Interfaces with single-mode optics use lasers as light sources. Lasers generate a single wavelength of light, which travels in a straight line through the single-mode fiber. Compared to multimode fiber, single-mode fiber has a higher bandwidth and can carry signals for longer distances. It is consequently more expensive.

For information about the maximum transmission distance and supported wavelength range for the types of single-mode and multimode fiber-optic cables that are connected to the NFX150 devices, see ["Pluggable Transceivers Supported on NFX150 Devices" on page 53](#). Exceeding the maximum transmission distances can result in significant signal loss, which causes unreliable transmission.

Attenuation and Dispersion in Fiber-Optic Cable

An optical data link functions correctly provided that modulated light reaching the receiver has enough power to be demodulated correctly. *Attenuation* is the reduction in strength of the light signal during transmission. Passive media components such as cables, cable splices, and connectors cause attenuation. Although attenuation is significantly lower for optical fiber than for other media, it still occurs in both multimode and single-mode transmission. An efficient optical data link must transmit enough light to overcome attenuation.

Dispersion is the spreading of the signal over time. The following two types of dispersion can affect signal transmission through an optical data link:

- Chromatic dispersion, which is the spreading of the signal over time caused by the different speeds of light rays.
- Modal dispersion, which is the spreading of the signal over time caused by the different propagation modes in the fiber.

For multimode transmission, modal dispersion, rather than chromatic dispersion or attenuation, usually limits the maximum bit rate and link length. For single-mode transmission, modal dispersion is not a factor. However, at higher bit rates and over longer distances, chromatic dispersion limits the maximum link length.

An efficient optical data link must have enough light to exceed the minimum power that the receiver requires to operate within its specifications. In addition, the total dispersion must be within the limits specified for the type of link in Telcordia Technologies document GR-253-CORE (Section 4.3) and International Telecommunications Union (ITU) document G.957.

When chromatic dispersion is at the maximum allowed, its effect can be considered as a power penalty in the power budget. The optical power budget must allow for the sum of component attenuation, power penalties (including those from dispersion), and a safety margin for unexpected losses.

Calculating the Fiber-Optic Cable Power Budget for an NFX150 Device

Calculate the link's power budget when planning fiber-optic cable layout and distances to ensure that fiber-optic connections have sufficient power for correct operation. The power budget is the maximum amount of power the link can transmit. When you calculate the power budget, you use a worst-case analysis to provide a margin of error, even though all the parts of an actual system do not operate at the worst-case levels.

To calculate the worst-case estimate for fiber-optic cable power budget (P^B) for the link:

1. Determine values for the link's minimum transmitter power (P_T) and minimum receiver sensitivity (P_R). For example, here, (P_T) and (P_R) are measured in decibels, and decibels are referenced to 1 milliwatt (dBm).

$$P_T = -15 \text{ dBm}$$

$$P_R = -28 \text{ dBm}$$

NOTE: See the specifications for your transmitter and receiver to find the minimum transmitter power and minimum receiver sensitivity.

2. Calculate the power budget (P^B) by subtracting (P_R) from (P_T):

$$-15 \text{ dBm} - (-28 \text{ dBm}) = 13 \text{ dBm}$$

Calculating the Fiber-Optic Cable Power Margin for an NFX150 Device

Before you begin to calculate the power margin:

- Calculate the power budget. See ["Calculating the Fiber-Optic Cable Power Budget for an NFX150 Device" on page 57.](#)

Calculate the link's power margin when planning fiber-optic cable layout and distances to ensure that fiber-optic connections have sufficient signal power to overcome system losses and still satisfy the minimum input requirements of the receiver for the required performance level. The power margin (P_M) is the amount of power available after attenuation or link loss (LL) has been subtracted from the power budget (P_B).

When you calculate the power margin, you use a worst-case analysis to provide a margin of error, even though all the parts of an actual system do not operate at worst-case levels. A power margin (P_M) greater than zero indicates that the power budget is sufficient to operate the receiver and that it does not exceed the maximum receiver input power. This means the link will work. A (P_M) that is zero or negative indicates insufficient power to operate the receiver. See the specification for your receiver to find the maximum receiver input power.

To calculate the worst-case estimate for the power margin (P_M) for the link:

1. Determine the maximum value for link loss (LL) by adding estimated values for applicable link-loss factors—for example, use the sample values for various factors as provided in [Table 24 on page 58](#) (here, the link is 2 km long and multimode, and the (P_B) is 13 dBm):

Table 24: Estimated Values for Factors Causing Link Loss

Link-Loss Factor	Estimated Link-Loss Value	Sample Link Loss (LL) Calculation Values
Higher-order mode losses	Multimode—0.5 dBm	0.5 dBm
	Single-mode—None	0 dBm
Modal and chromatic dispersion	Multimode—None, if product of bandwidth and distance is less than 500 MHz/km	0 dBm
	Single-mode—None	0 dBm

Table 24: Estimated Values for Factors Causing Link Loss (*Continued*)

Link-Loss Factor	Estimated Link-Loss Value	Sample Link Loss (LL) Calculation Values
Connector	0.5 dBm	This example assumes five connectors. Loss for five connectors: 5 (0.5 dBm) = 2.5 dBm.
Splice	0.5 dBm	This example assumes two splices. Loss for two splices: 2 (0.5 dBm) = 1 dBm.
Fiber attenuation	Multimode—1 dBm/km	This example assumes the link is 2 km long. Fiber attenuation for 2 km: 2 km (1 dBm/km) = 2 dBm.
	Single-mode—0.5 dBm/km	This example assumes the link is 2 km long. Fiber attenuation for 2 km: 2 km (0.5 dBm/km) = 1 dBm.
Clock Recovery Module (CRM)	1 dBm	1 dBm

NOTE: For information about the actual amount of signal loss caused by equipment and other factors, see your vendor documentation for that equipment.

2. Calculate the (P_M) by subtracting (LL) from (P_B):

$$P_B - LL = P_M$$

$$13 \text{ dBm} - 0.5 \text{ dBm [HOL]} - 5 (0.5 \text{ dBm}) - 2 (0.5 \text{ dBm}) - 2 \text{ km (1.0 dBm/km)} - 1 \text{ dB [CRM]} = P_M$$

$$13 \text{ dBm} - 0.5 \text{ dBm} - 2.5 \text{ dBm} - 1 \text{ dBm} - 2 \text{ dBm} - 1 \text{ dBm} = P_M$$

$$P_M = 6 \text{ dBm}$$

The calculated power margin is greater than zero, indicating that the link has sufficient power for transmission. Also, the power margin value does not exceed the maximum receiver input power. Refer to the specifications for your receiver to find the maximum receiver input power.

NFX150 Cable Specifications and Pinouts

IN THIS SECTION

- [Cable Specifications for Console and Management Connections for the NFX150 Devices | 60](#)
- [Mini-USB Type-B Console Port Specifications for an NFX150 Device | 61](#)
- [Console Port Connector Pinouts for NFX150 Devices | 62](#)
- [USB Port Specifications for an NFX150 Device | 63](#)
- [Management Port Connector Pinout Information for an NFX150 Device | 64](#)
- [Network Port Connector Pinout Information for an NFX150 Device | 65](#)
- [RJ-45 to DB-9 Serial Port Adapter Pinout Information for an NFX150 Device | 67](#)

Cable Specifications for Console and Management Connections for the NFX150 Devices

[Table 25 on page 60](#) lists the specifications for the cables that connect the NFX150 devices to a management device.

Table 25: Cable Specifications for Console and Management Connections for the NFX150 Devices

Port on NFX150 Device	Cable Specification	Maximum Length	Device Receptacle
Console port	RS-232 (EIA-232) serial cable	7 feet (2.13 meters)	RJ-45
Management port	Category 5 cable or equivalent suitable for 1000BASE-T operation	328 feet (100 meters)	RJ-45

NOTE: We no longer include the console cable as part of the device package. If the console cable and adapter are not included in your device package, or if you need a different type of adapter, you can order the following separately:

- RJ-45 to DB-9 adapter (JNP-CBL-RJ45-DB9)
- RJ-45 to USB-A adapter (JNP-CBL-RJ45-USBA)
- RJ-45 to USB-C adapter (JNP-CBL-RJ45-USBC)

If you want to use RJ-45 to USB-A or RJ-45 to USB-C adapter you must have X64 (64-Bit) Virtual COM port (VCP) driver installed on your PC. See, <https://ftdichip.com/drivers/vcp-drivers/> to download the driver.

SEE ALSO

[Console Port Connector Pinouts for NFX150 Devices | 62](#)

[Management Port Connector Pinout Information for an NFX150 Device | 64](#)

[Connecting an NFX150 Device to a Management Console | 91](#)

[Connecting an NFX150 Device to a Network for Out-of-Band Management | 90](#)

Mini-USB Type-B Console Port Specifications for an NFX150 Device

The NFX150 device has two console ports: an RJ-45 port and a Mini-USB port.

By default, the RJ-45 port is set as the active console port. It can display all the early boot and low-level message output and you can access the device through this port in the debugger prompt.

The Mini-USB port is the passive console port. You can change the status of the port to active or passive using the `port-type` configuration statement. See [Configuring the Console Port Type \(CLI Procedure\)](#).

The Mini-USB console port uses a Mini-B plug (5-pin) connector to connect to a console management device. The default baud rate for the console port is 9600 baud.

[Table 26 on page 61](#) provides the pinout information of the Mini-USB Type-B console port.

Table 26: Mini-USB Type-B Console Port Pinout Information for NFX150 Devices

Pin	Signal	Description
1	VCC	+5 VDC

Table 26: Mini-USB Type-B Console Port Pinout Information for NFX150 Devices *(Continued)*

Pin	Signal	Description
2	D-	Data -
3	D+	Data +
X	N/C	May be N/C, GND or used as an attached device presence indicator
4	GND	Ground

SEE ALSO

| [NFX150 Network Services Platform Overview | 2](#)

Console Port Connector Pinouts for NFX150 Devices

The console port (labeled **CON**) is an RS-232 serial interface that uses an RJ-45 connector to connect to a console management device. The default baud rate for the console port is 9600 baud.

[Table 27 on page 62](#) provides the pinout information for the RJ-45 console connector.

NOTE: If your laptop or PC does not have a DB-9 plug connector pin and you want to connect your laptop or PC directly to an NFX150 device, use a combination of the RJ-45 cable and RJ-45 to DB-9 adapter and a USB to DB-9 plug adapter. You must provide the USB to DB-9 plug adapter.

Table 27: Console Port Connector Pinouts for the NFX150 Device

Pin	Signal	Description
1	RTS Output	Request to send

Table 27: Console Port Connector Pinouts for the NFX150 Device (Continued)

Pin	Signal	Description
2	DTR Output	Data terminal ready
3	TxD Output	Transmit data
4	Signal Ground	Signal ground
5	Signal Ground	Signal ground
6	RxD Input	Receive data
7	DCD Input	Data carrier detect
8	CTS Input	Clear to send

SEE ALSO

| [Connecting an NFX150 Device to a Management Console | 91](#)

USB Port Specifications for an NFX150 Device

The following Juniper Networks USB flash drives have been tested and are officially supported for the USB port in the NFX150 devices:

- RE-USB-1G-S—1-gigabyte (GB) USB flash drive
- RE-USB-2G-S—2-GB USB flash drive
- RE-USB-4G-S—4-GB USB flash drive



CAUTION: Any USB memory product not listed as supported for the NFX150 device has not been tested by Juniper Networks. The use of any unsupported USB memory product could expose your device to unpredictable behavior. Juniper Networks Technical Assistance Center (JTAC) can provide only limited support for issues related to unsupported hardware. We strongly recommend that you use only supported USB flash drives.



CAUTION: Remove the USB flash drive before upgrading Junos OS or rebooting a NFX150 device. Failure to do so could expose your device to unpredictable behavior.

NOTE: Executing the `request system snapshot` CLI command on a NFX150 device requires an external USB flash drive with at least 4 GB of free space. We recommend using the RE-USB-4G-S flash drive.

NOTE: USB flash drives used with the NFX150 device must support USB 2.0 or later.

SEE ALSO

[NFX150 Chassis | 10](#)

Management Port Connector Pinout Information for an NFX150 Device

The 1000BASE-T RJ-45 management port on an NFX150 device uses an RJ-45 connector to connect to a management device for out-of-band management.

[Table 28 on page 64](#) provides the pinout information of the RJ-45 management port connector.

Table 28: RJ-45 Management Port Connector Pinouts for the NFX150 Devices

Pin	Signal	Description
1	TRP1+	Transmit/receive data pair 1

Table 28: RJ-45 Management Port Connector Pinouts for the NFX150 Devices (Continued)

Pin	Signal	Description
2	TRP1-	Transmit/receive data pair 1
3	TRP2+	Transmit/receive data pair 2
4	TRP3+	Transmit/receive data pair 3
5	TRP3-	Transmit/receive data pair 3
6	TRP2-	Transmit/receive data pair 2
7	TRP4+	Transmit/receive data pair 4
8	TRP4-	Transmit/receive data pair 4

SEE ALSO

| [LED Details of an NFX150 Device](#) | 20

Network Port Connector Pinout Information for an NFX150 Device

A network port on an NFX150 device uses an RJ-45 connector to connect to a device.

The port uses an autosensing RJ-45 connector to support a 10/100/1000Base-T connection. Two LEDs on the port indicate link/activity on the port and the port status. See "[LED Details of an NFX150 Device](#)" on page 20.

[Table 29 on page 66](#) provides the pinout information for the RJ-45 connector.

Table 29: Network Port Connector Pinout Information for NFX150 Devices

Pin	Signal	Description
1	TRP1+	Transmit/receive data pair 1 Negative Vport (in PoE models)
2	TRP1-	Transmit/receive data pair 1 Negative Vport (in PoE models)
3	TRP2+	Transmit/receive data pair 2 Positive Vport (in PoE models)
4	TRP3+	Transmit/receive data pair 3
5	TRP3-	Transmit/receive data pair 3
6	TRP2-	Transmit/receive data pair 2 Positive Vport (in PoE models)
7	TRP4+	Transmit/receive data pair 4
8	TRP4-	Transmit/receive data pair 4

SEE ALSO

[NFX150 Network Services Platform Overview | 2](#)

RJ-45 to DB-9 Serial Port Adapter Pinout Information for an NFX150 Device

The console port is an RS-232 serial interface that uses an RJ-45 connector to connect to a management device such as a PC or a laptop. If your laptop or PC does not have a DB-9 plug connector pin and you want to connect your laptop or PC to an NFX150 device, use a combination of the RJ-45 to DB-9 socket adapter along with a USB to DB-9 plug adapter.

[Table 30 on page 67](#) provides the pinout information for the RJ-45 to DB-9 serial port adapter.

Table 30: RJ-45 to DB-9 Serial Port Adapter Pinout Information

RJ-45 Pin	Signal	DB-9 Pin	Signal
1	RTS	8	CTS
2	DTR	6	DSR
3	TXD	2	RXD
4	GND	5	GND
6	RXD	3	TXD
7	DSR	4	DTR
8	CTS	7	RTS

SEE ALSO

[Connecting an NFX150 Device to a Management Console | 91](#)

3

CHAPTER

Initial Installation and Configuration

NFX150 Installation Overview | 69

Unpacking and Mounting the NFX150 | 70

Connecting the NFX150 to Power | 85

Connecting the NFX150 to the Network | 90

Initial Configuration on NFX150 Devices | 98

Installing and Configuring the NFX150 Expansion Modules | 103

NFX150 Installation Overview

To install and connect an NFX150 device:

1. Follow instructions in ["Unpacking an NFX150 Device" on page 70](#).
2. Mount the device by following instructions appropriate for your site:
 - ["Mounting an NFX150 Device on a Desk or Other Level Surface" on page 74](#) (using the rubber feet provided)
 - ["Mounting an NFX150 Device on Two Posts in a Rack" on page 80](#) (using the mounting brackets provided)
 - ["Mounting an NFX150 Device on Four Posts in a Rack or Cabinet" on page 83](#) (using the separately orderable four-post rack-mount kit)
 - ["Mounting an NFX150 Device on a Wall" on page 76](#) (using the separately orderable wall-mount kit)
3. Follow instructions in ["Connecting Earth Ground to an NFX150 Device" on page 86](#).
4. Follow instructions in ["Connecting AC Power to an NFX150 Device" on page 88](#).
5. Perform initial configuration of the device by following instructions in [Configuring an NFX150 Device](#).
6. Set the device's management options by following the appropriate instructions:
 - ["Connecting an NFX150 Device to a Management Console" on page 91](#)
 - ["Connecting an NFX150 Device to a Network for Out-of-Band Management" on page 90](#)

RELATED DOCUMENTATION

[Rack Requirements for NFX150 Devices | 49](#)

[Cabinet Requirements for an NFX150 Device | 51](#)

[Clearance Requirements for Airflow and Hardware Maintenance for an NFX150 Device | 46](#)

Unpacking and Mounting the NFX150

IN THIS SECTION

- [Unpacking an NFX150 Device | 70](#)
- [Parts Inventory \(Packing List\) for an NFX150 Device | 71](#)
- [Register Products—Mandatory to Validate SLAs | 72](#)
- [Mounting an NFX150 Device | 73](#)
- [Mounting an NFX150 Device on a Desk or Other Level Surface | 74](#)
- [Mounting an NFX150 Device on a Wall | 76](#)
- [Mounting an NFX150 Device on Two Posts in a Rack | 80](#)
- [Mounting an NFX150 Device on Four Posts in a Rack or Cabinet | 83](#)

Unpacking an NFX150 Device

The NFX150 devices are shipped in a cardboard carton, secured with foam packing material. The carton has an accessory compartment and contains the quick start instructions.



CAUTION: NFX150 devices are maximally protected inside the shipping carton. Do not unpack the devices until you are ready to begin installation.

To unpack the device:

1. Open the carton.
2. Pull out the packing material holding the device in place.
3. Verify the parts received against the inventory on the label attached to the carton. See "[Parts Inventory \(Packing List\) for an NFX150 Device](#)" on page 71.
4. Save the shipping carton and packing materials in case you need to move or ship the device later.

SEE ALSO

| [NFX150 Network Services Platform Overview | 2](#)

Parts Inventory (Packing List) for an NFX150 Device

The device shipment includes a packing list. Check the parts you receive in the device shipping carton against the items on the packing list. The parts shipped depend on the configuration you order.

If any part on the packing list is missing, contact your customer service representative or contact Juniper customer care from within the U.S. or Canada by telephone at 1-888-314-5822. For international-dial or direct-dial options in countries without toll-free numbers, see <https://www.juniper.net/support/requesting-support.html>.

Table 31 on page 71 lists the parts and their quantities in the packing list.

Table 31: Packing List for an NFX150 Device

Component	Quantity
Device	1
AC power cord appropriate for your geographical location	1
AC power cord retainer clip	1 NOTE: The AC power cord retainer clip is provided only with NFX150-S1 device.
Mounting brackets	2
Mounting screws to attach the mounting brackets to the device chassis	8
Rubber feet	4
Quick Start installation instructions	1
Juniper Networks Product Warranty	1
End User License Agreement	1

NOTE: We no longer include the console cable as part of the device package. If the console cable and adapter are not included in your device package, or if you need a different type of adapter, you can order the following separately:

- RJ-45 to DB-9 adapter (JNP-CBL-RJ45-DB9)
- RJ-45 to USB-A adapter (JNP-CBL-RJ45-USBA)
- RJ-45 to USB-C adapter (JNP-CBL-RJ45-USBC)

If you want to use RJ-45 to USB-A or RJ-45 to USB-C adapter you must have X64 (64-Bit) Virtual COM port (VCP) driver installed on your PC. See, <https://ftdichip.com/drivers/vcp-drivers/> to download the driver.

NOTE: You must provide mounting screws that are appropriate for your rack or cabinet to mount the chassis on a rack or a cabinet.

SEE ALSO

| [NFX150 Network Services Platform Overview](#) | 2

Register Products—Mandatory to Validate SLAs

Register all new Juniper Networks hardware products and changes to an existing installed product using the Juniper Networks website to activate your hardware replacement service-level agreements (SLAs).



CAUTION: Register product serial numbers on the Juniper Networks website. Update the installation base data if any addition or change to the installation base occurs or if the installation base is moved. Juniper Networks is not responsible for not meeting the hardware replacement service-level agreement for products that do not have registered serial numbers or accurate installation base data.

Register your product(s) at <https://tools.juniper.net/svcreg/SRegSerialNum.jsp>.

Update your installation base at <https://www.juniper.net/customers/csc/management/updateinstallbase.jsp>.

Mounting an NFX150 Device

Table 32 on page 73 lists the methods you can use to mount an NFX150 device.

Table 32: NFX150 Device Mounting Methods

Mounting Method	Device Model	Comments
Desk or other level surface (using rubber feet)	<ul style="list-style-type: none"> • NFX150-C-S1 • NFX150-C-S1-AE • NFX150-C-S1-AA • NFX150-C-S1E-AE • NFX150-C-S1E-AA 	On a desk or other level surface by using rubber feet provided with the device.
Two-post rack or cabinet	<ul style="list-style-type: none"> • NFX150-S1 • NFX150-S1E 	On two posts in a rack or cabinet by using the mounting brackets.
Four-post rack or cabinet	<ul style="list-style-type: none"> • NFX150-S1 • NFX150-S1E 	On four posts in a rack or cabinet by using the mounting brackets.
Wall mounting	<ul style="list-style-type: none"> • NFX150-S1 • NFX150-S1E • NFX150-C-S1 • NFX150-C-S1-AE • NFX150-C-S1-AA • NFX150-C-S1E-AE • NFX150-C-S1E-AA 	On a wall by using wall mounting brackets.

The holes in the mounting brackets are placed at 1 U (1.75 in. or 4.45 cm) apart so that the device can be mounted in any rack or cabinet that provides holes spaced at that distance.

See the Related Documentation for detailed descriptions of the various rack or cabinet mounting options.

SEE ALSO

[Mounting an NFX150 Device on a Desk or Other Level Surface | 74](#)

[Mounting an NFX150 Device on Two Posts in a Rack | 80](#)

[Mounting an NFX150 Device on Four Posts in a Rack or Cabinet | 83](#)

[Mounting an NFX150 Device on a Wall | 76](#)

[Connecting Earth Ground to an NFX150 Device | 86](#)

Mounting an NFX150 Device on a Desk or Other Level Surface

Before mounting the device on a desk or other level surface:

- Verify that the site meets the requirements described in "[Site Preparation Checklist for NFX150 Devices](#)" on page 40.
- Place the desk in its permanent location, allowing adequate clearance for airflow and maintenance, and secure it to the building structure.
- Read *General Safety Guidelines and Warnings*, with particular attention to "[Chassis Lifting Guidelines for NFX150 Devices](#)" on page 145.
- Ensure that you have the 4 rubber feet to stabilize the chassis on the a desk or other level surface (provided in the accessory box in the device carton)

You can mount an NFX150-C-S1 device on a desk or other level surface by using the four rubber feet that are shipped with the device. The rubber feet stabilize the chassis.

To mount an NFX150-C-S1 device on a desk or other level surface:

1. Remove the device from the shipping carton (see "[Unpacking an NFX150 Device](#)" on page 70).
2. Turn the chassis upside down on the desk or the level surface where you intend to mount the device.
3. Attach the rubber feet to the bottom of the chassis as shown in [Figure 20 on page 75](#)
4. Turn the chassis right side up on the desk or the level surface.

Figure 20: Attaching Rubber Feet to the NFX150-C-S1 Device

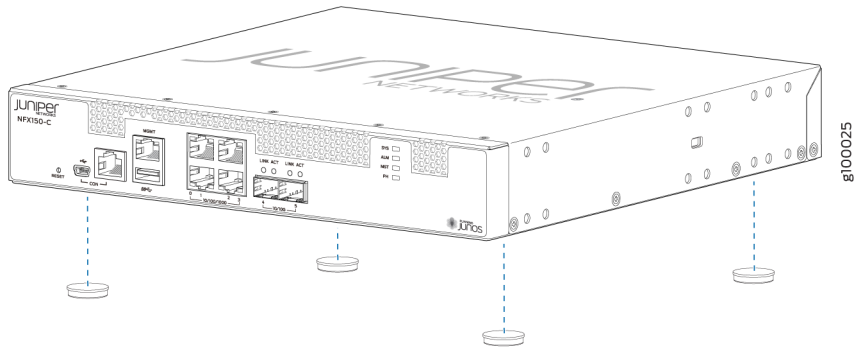

5. Attach the antennas to the antenna base of compact models such as NFX150-C-S1-AA and NFX150-C-S1-AE with integrated LTE modem support. See [Figure 21 on page 75](#).

Figure 21: Attaching Antennas to NFX150-C-S1-AA and NFX150-C-S1-AE

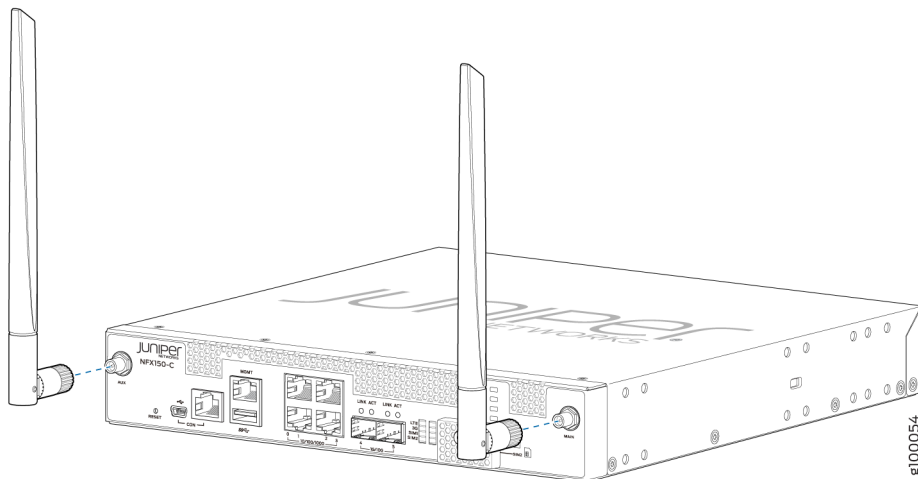

SEE ALSO

[Connecting Earth Ground to an NFX150 Device | 86](#)

[Connecting AC Power to an NFX150 Device | 88](#)

[Clearance Requirements for Airflow and Hardware Maintenance for an NFX150 Device | 46](#)

Mounting an NFX150 Device on a Wall

Before mounting an NFX150 device on a wall:

- Verify that the site meets the requirements described in ["Site Preparation Checklist for NFX150 Devices"](#) on page 40.
- Read [General Safety Guidelines and Warnings](#), with particular attention to ["Chassis Lifting Guidelines for NFX150 Devices"](#) on page 145.
- Remove the device from the shipping carton (see ["Unpacking an NFX150 Device"](#) on page 70).

Ensure that you have the following parts and tools available:

- Phillips (+) screwdriver, number 2
- 2 wall-mount brackets (provided with the wall-mount kit)
- 8 wall-mount bracket screws (provided with the wall-mount kit)
- 4 mounting screws (8-32 x 1.25 in. or M4 x 30 mm) (not included)
- Hollow wall anchors capable of supporting the weight of a fully loaded NFX150 device, up to 9 lb (4 kg) (not included)—if you are mounting the device in sheetrock (wall board with a gypsum plaster core) or in wall board not backed by wall studs

You can mount an NFX150 device on a wall by using the separately orderable wall-mount kit.

To mount the device on a wall:

1. Attach the wall-mount brackets to the sides of the chassis using four of the wall-mount bracket screws on each side, as shown in [Figure 22 on page 76](#) and [Figure 23 on page 77](#).

Figure 22: Attaching Wall-Mount Brackets to the NFX150 Device Chassis

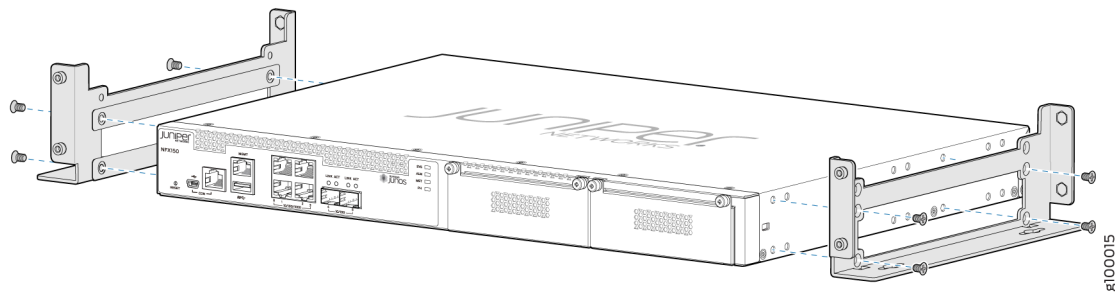
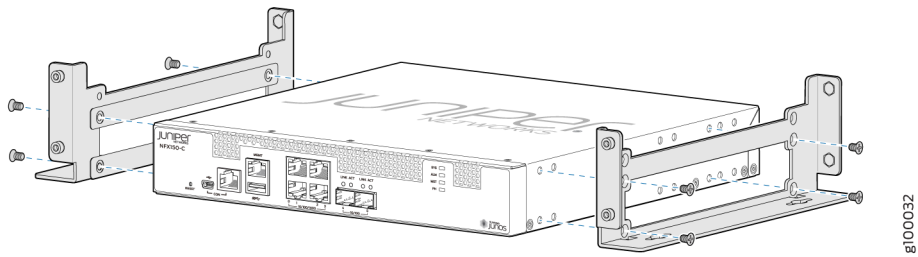

Figure 23: Attaching Wall-Mount Brackets to the NFX150-C-S1 Device Chassis



2. Install four mounting screws on the wall as shown in [Figure 24 on page 77](#) and [Figure 25 on page 78](#).

Figure 24: Measurements for Installing Mounting Screws for NFX150-S1 Device on a Wall

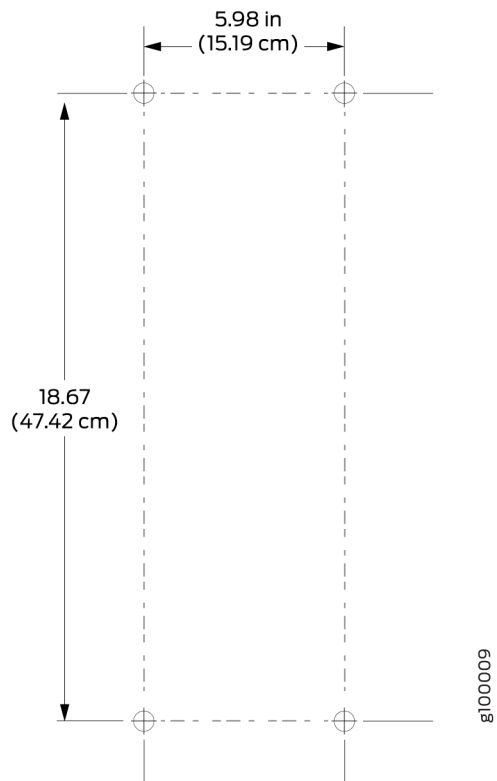
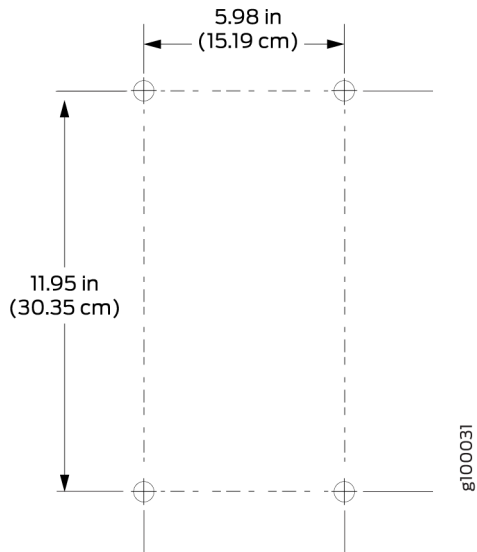
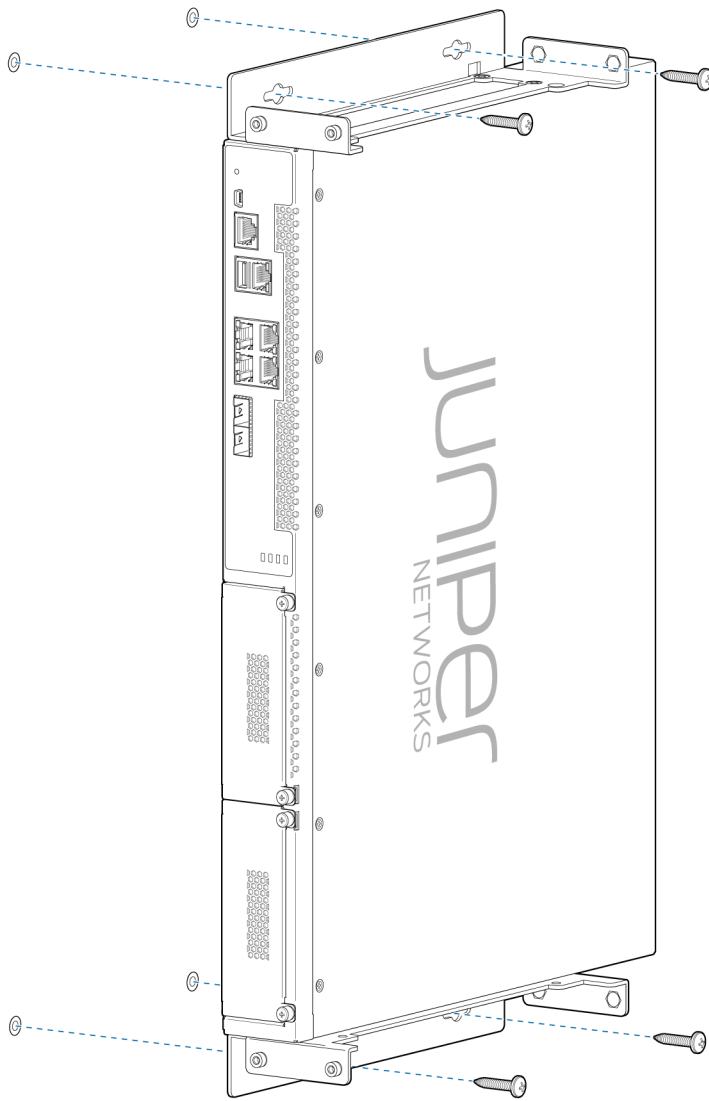

Figure 25: Measurements for Installing Mounting Screws for NFX150-C-S1 Device on a Wall



- a. Drill a hole A and install a mounting screw.
 - b. Drill a hole B at a distance of 5.98 in. (15.19 cm.) on a level line to the right from hole A and install a mounting screw.
 - c. Drill two holes at a distance of 18.67 in. (47.42 cm) on a plumb line from hole A and B, install the mounting screws.
 - d. Screw the mounting screws only part way in, leaving about 1/4 in. (6 mm) distance between the head of the screw and the wall.
3. If the mounting screws are inserted in wall board with no stud behind it, you must use dry wall anchors rated to support 20 lb (9 kg). Insert the screws into wall studs wherever possible to provide added support for the chassis.
 4. Grasp each side of the device, lift the device, and hang the brackets from the mounting screws such that the front panel of the device faces to your right or left side as shown in [Figure 26 on page 79](#) and [Figure 27 on page 80](#).

Figure 26: Mounting the NFX150-S1 Device on a Wall



9100018

Figure 27: Mounting the NFX150-C-S1 Device on a Wall

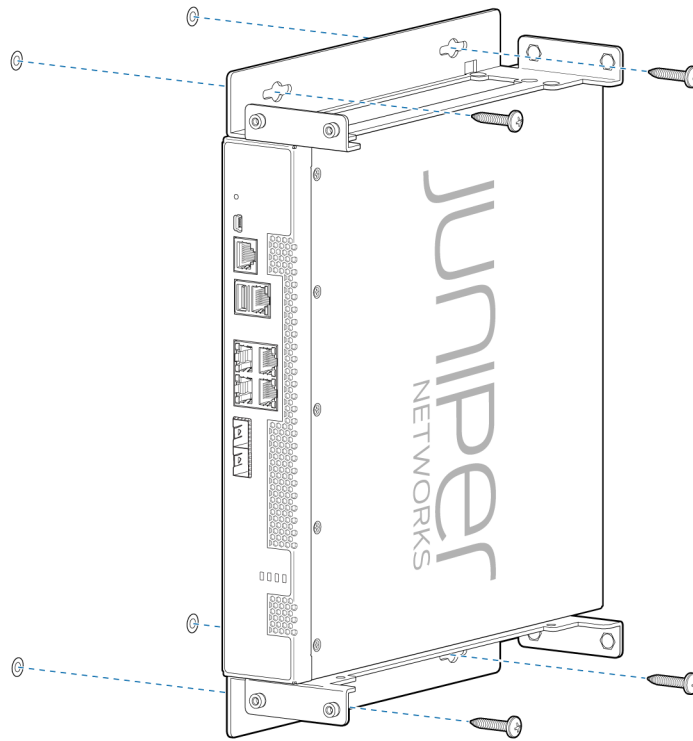

g100033

5. Tighten the mounting screws.

SEE ALSO

[Initial Configuration on NFX150 Devices](#) | 98

Mounting an NFX150 Device on Two Posts in a Rack

Before mounting an NFX150 device on two posts in a rack:

- Place the rack in its permanent location, allowing adequate clearance for airflow and maintenance, and secure it to the building structure.
- Read [General Safety Guidelines and Warnings](#).
- Remove the device from the shipping carton.

Ensure that you have the following parts and tools available:

- Phillips (+) screwdriver, number 2
- 2 mounting brackets and 8 mounting screws (provided in the accessory box shipped with the device)
- Screws to secure the chassis to the rack (not provided)

You can mount an NFX150 device on two posts of a 19-in. rack (either a two-post or a four-post rack).

NOTE: If you need to mount the device in a recessed position on either a two-post rack or a four-post rack, you can use the 2-in.-recess front brackets provided in the separately orderable four-post rack-mount kit.

NOTE: One person must be available to lift the device while another secures the device to the rack.



CAUTION: If you are mounting multiple devices on a rack, mount a device in the bottom of the rack first and proceed to mount the rest of the devices from bottom to top.

To mount the device on two posts in a rack:

1. Place the device on a flat, stable surface.
2. Align the mounting brackets along the front, rear, or center of the side panels of the device chassis depending on how you want to mount the device. For example, if you want to front-mount the device, align the brackets along the front of the side panel. See [Figure 28 on page 81](#).

Figure 28: Attaching the Mounting Bracket to the Side Panel of the Device

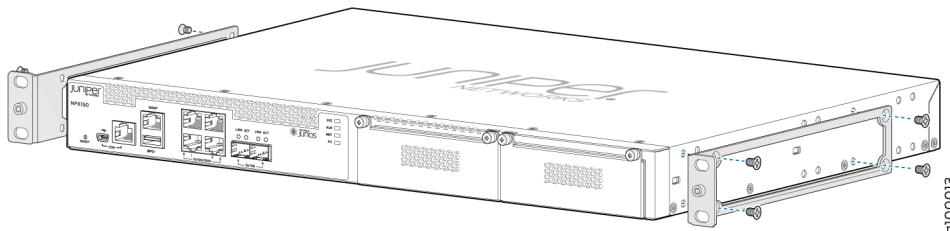

NOTE: If you need to mount the device in a recessed position, use the 2-in.-recess front mount brackets from the separately orderable four-post rack-mount kit.

3. Align the bottom holes in the mounting brackets with holes on the side panels of the device chassis.
4. Insert mounting screws into the aligned holes. Tighten the screws.
5. Ensure that the other holes in the mounting brackets are aligned with the holes in the side panels. Insert a screw in each hole and tighten the screws.
6. Have one person grasp both sides of the device, lift the device, and position it in the rack, aligning the mounting bracket holes with the threaded holes in the rack or cabinet rail. Align the bottom hole in both the mounting brackets with a hole in each rack rail, making sure the chassis is level. See [Figure 29 on page 82](#).

Figure 29: Mounting the Device on Two Posts in a Rack

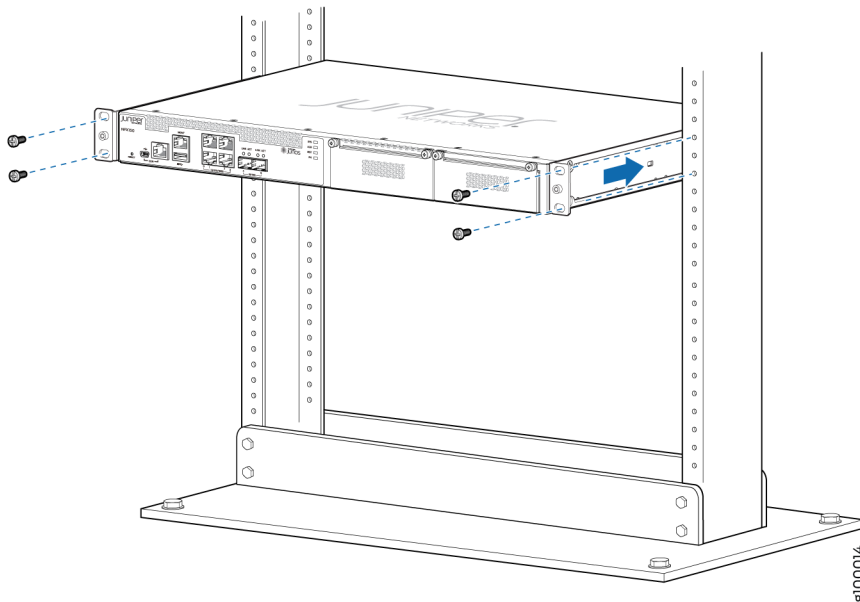

7. Have a second person secure the device to the rack by using the appropriate screws. Tighten the screws.
8. Ensure that the device chassis is level by verifying that all screws on one side of the rack are aligned with the screws on the other side.

SEE ALSO

[Connecting AC Power to an NFX150 Device](#) | 88

Mounting an NFX150 Device on Four Posts in a Rack or Cabinet

Before mounting the device on four posts in a rack:

- Place the rack in its permanent location, allowing adequate clearance for airflow and maintenance, and secure it to the building structure.
- Read [General Safety Guidelines and Warnings](#), with particular attention to "[Chassis Lifting Guidelines for NFX150 Devices](#)" on page 145.
- Remove the device from the shipping carton (see "[Unpacking an NFX150 Device](#)" on page 70).
- Have two persons available to mount the device. One person will support the device in a level position, and the second person will secure the device to the rack.

Ensure that you have the following parts and tools available:

- Phillips (+) screwdriver, number 2
- 12 flat-head M4x6-mm Phillips mounting screws (provided with the four-post rack-mount kit)
- One pair of front-mounting brackets
- One pair of rear mounting-blades
- Screws to secure the front-mounting brackets and the rear mounting-blades to the rack (not provided)

You can mount an NFX150 device on four posts of a 19-in. rack or cabinet by using the separately orderable four-post rack-mount kit. (The remainder of this topic uses *rack* to mean *rack or cabinet*).

You can mount the device on two posts in either a two-post rack or a four-post rack by using the mounting brackets provided with the device. See "[Mounting an NFX150 Device on Two Posts in a Rack](#)" on page 80.

NOTE: If you are mounting the device on four posts, ensure that the rack is 21.5 in. through 31.5 in. deep if you will mount the device flush with the rack front and that the rack is 23.5 in. through 32.5 in. deep if you will mount the device 2 in. recessed from the rack front, thus

ensuring that the protective earthing terminal is accessible through the opening in the rear mounting-blade.



CAUTION: If you are mounting multiple units on a rack, mount the heaviest unit at the bottom of the rack and mount the other units from the bottom of the rack to the top in decreasing order of the weight of the units.

To mount the device on four posts in a rack:

1. Place the device on a flat, stable surface.
2. Align a front bracket (either flush with the front of the chassis or 2-in.-recessed from the front of the chassis) along the side panel of the device chassis. Align the two holes in the front of the brackets with the two holes on the front of the side panel.

NOTE: Each side of the chassis has twelve holes for attaching the front-mounting brackets to the device.

Six holes on the chassis side align with six holes in the front bracket when the front bracket is mounted flush with the chassis front or recessed 2 in. from the front of the chassis.

3. Insert M4x6-mm Phillips flat-head mounting screws into the two aligned holes and tighten the screws. Ensure that the remaining two holes in the front bracket are aligned with the two holes in the side panel. See [Figure 30 on page 84](#).

Figure 30: Attaching the Front-Mounting Bracket to the Device Chassis

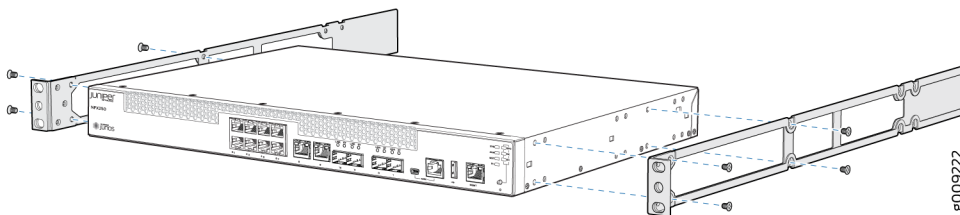

4. Insert M4x6-mm Phillips flat-head mounting screws into the remaining two holes in the front bracket and tighten the screws.
5. Repeat steps 2 through 4 for attaching the front bracket to the other side of the chassis.
6. Have one person grasp both sides of the device, lift the device, and position it in the rack, aligning the front bracket holes with the threaded holes in the front post of the rack. Align the bottom hole

in both the front-mounting brackets with a hole in each rack rail, making sure the chassis is level. See [Figure 31 on page 85](#).

Figure 31: Mounting the Device on the Front Posts in a Rack

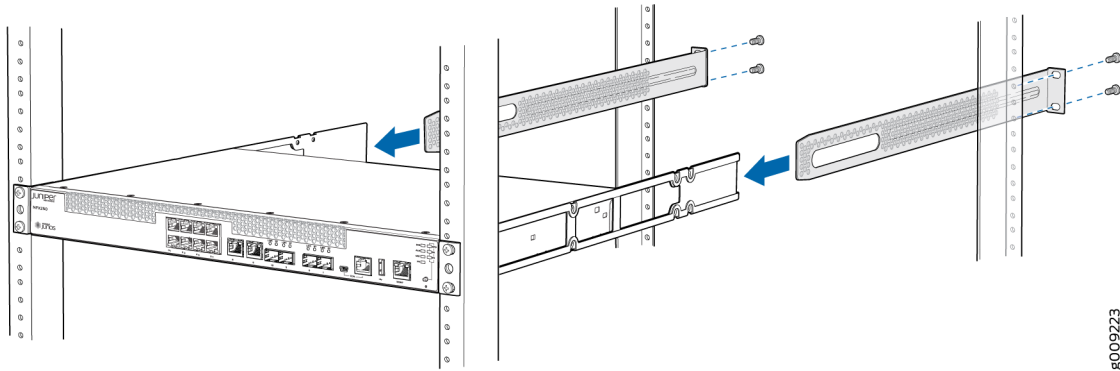

7. Have a second person secure the front of the device to the rack by using the appropriate screws for your rack.
8. Slide the rear mounting-blades into the front-mounting brackets.
9. Attach the rear mounting-blades to the rear post by using the appropriate screws for your rack. Tighten the screws.
10. Ensure that the device chassis is level by verifying that all the screws on the front of the rack are aligned with the screws at the back of the rack.

SEE ALSO

[Connecting Earth Ground to an NFX150 Device | 86](#)

[Connecting AC Power to an NFX150 Device | 88](#)

[Rack-Mounting and Cabinet-Mounting Warnings | 147](#)

Connecting the NFX150 to Power

IN THIS SECTION

- [Connecting Earth Ground to an NFX150 Device | 86](#)

- [Connecting AC Power to an NFX150 Device | 88](#)

Connecting Earth Ground to an NFX150 Device

IN THIS SECTION

- [Parts and Tools Required for Connecting an NFX150 Device to Earth Ground | 86](#)
- [Connecting Earth Ground to an NFX150 Device | 87](#)

. Electromagnetic Compatibility (EMC) and Electrostatic Discharge (ESD) requirements are met by the device chassis. The AC power cord provides surge protection.

You must install the NFX150 device in a restricted-access location and ensure that the chassis is always properly grounded. The NFX150 device has a two-hole protective grounding terminal provided on the chassis. See [Figure 32 on page 88](#) and [Figure 33 on page 88](#). We recommend that you use this protective grounding terminal as the preferred method for grounding the chassis regardless of the power supply configuration. However, if additional grounding methods are available, you can also use those methods. For example, you can use the grounding wire in the AC power cord or use the grounding terminal or lug on a DC power supply. This tested system meets or exceeds all applicable EMC regulatory requirements with the two-hole protective grounding terminal.

This topic describes:

Parts and Tools Required for Connecting an NFX150 Device to Earth Ground

[Table 33 on page 87](#) lists the earthing terminal location, grounding cable requirements, grounding lug specifications, screws and washers required, and the screwdriver needed for connecting a device to earth ground. Before you begin connecting a device to earth ground, ensure you have the parts and tools required for your device.

Table 33: Parts and Tools Required for Connecting an NFX150 Device to Earth Ground

Device	Earthing Terminal Location	Grounding Cable Requirements	Grounding Lug Specifications	Screws and Washers	Screwdriver
NFX150-S1	Rear panel of chassis	14 AWG (2 mm ²), minimum 90°C wire, or as permitted by the local code	Panduit LCC10-14BWL or equivalent—not provided	<ul style="list-style-type: none"> • Two 10-32 x .25 in. screws with #10 split-lock washer—not provided • Two #10 flat washers—not provided 	Phillips (+) number 2
NFX150-C-S1	Rear panel of chassis	14 AWG (2 mm ²), minimum 90°C wire, or as permitted by the local code	Panduit LCC10-14BWL or equivalent—not provided	<ul style="list-style-type: none"> • Two 10-32 x .25 in. screws with #10 split-lock washer—not provided • Two #10 flat washers—not provided 	Phillips (+) number 2

Connecting Earth Ground to an NFX150 Device

To connect earth ground to a device:

1. Connect one end of the grounding cable to a proper earth ground, such as the rack in which the device is mounted.
2. Place the grounding lug attached to the grounding cable over the protective earthing terminal. See [Figure 32 on page 88](#) and [Figure 33 on page 88](#).

Figure 32: Connecting a Grounding Cable to an NFX150-S1 Device

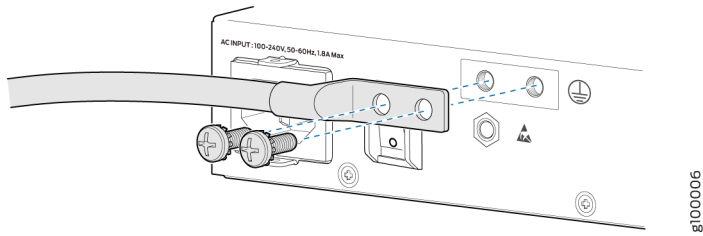
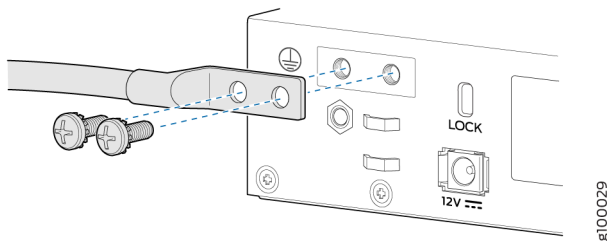

Figure 33: Connecting a Grounding Cable to an NFX150-C-S1 Device



3. Secure the grounding lug to the protective earthing terminal with the washers and screws.
4. Dress the grounding cable and ensure that it does not touch or block access to other device components.



WARNING: Ensure that the cable does not drape where people could trip over it.

Connecting AC Power to an NFX150 Device

Ensure that you have the following parts and tools available:

- A power cord appropriate for your geographical location
- A power cord retainer clip



CAUTION: NFX150 device gets additional grounding when you plug the power supply in the device into a grounded AC power outlet by using the AC power cord appropriate for your geographical location (see ["AC Power Cord Specifications for an NFX150 Device" on page 35](#)).

The power supply in an NFX150 device is located on the rear panel.

To connect AC power to the device:

1. Squeeze the two sides of the power cord retainer clip and insert the L-shaped ends of the wire clip into the holes in the bracket on each side of the AC power cord inlet on the rear panel.

The power cord retainer clip extends out of the chassis by 3 in.

2. Locate the power cord or cords shipped with the device; the cords have plugs appropriate for your geographical location. See ["AC Power Cord Specifications for an NFX150 Device" on page 35](#).



WARNING: Ensure that the power cord does not drape where people can trip on it or block access to device components.

3. Insert the coupler end of the power cord into the AC power cord inlet on the rear panel.
4. Push the power cord into the slot in the adjustment nut of the power cord retainer clip. Turn the nut until it is tight against the base of the coupler and the slot in the nut is turned 90° from the top of the device.
5. If the AC power source outlet has a power switch, set it to the OFF (O) position.
6. Insert the power cord plug into an AC power source outlet.
7. If the AC power source outlet has a power switch, set it to the ON (I) position.

NOTE: The retainer brackets on your device might be above and below the power inlet rather than on either side.

Figure 34: Connecting an AC Power Cord to the AC Power Cord Inlet on NFX150 Device

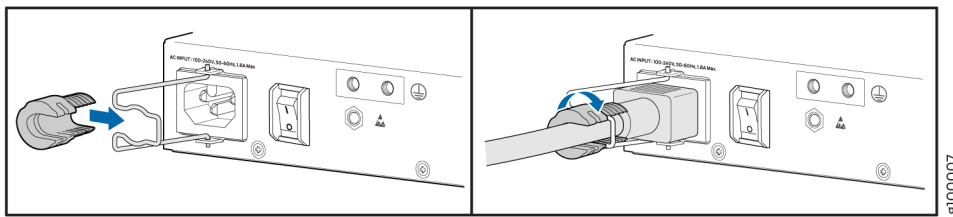

SEE ALSO

[AC Power Supply Specifications for an NFX150 Device | 35](#)

[AC Power Cord Specifications for an NFX150 Device | 35](#)

Connecting the NFX150 to the Network

IN THIS SECTION

- [Connecting an NFX150 Device to a Network for Out-of-Band Management | 90](#)
- [Connecting an NFX150 Device to a Management Console | 91](#)
- [Connecting an NFX150 Device to a Management Console Using Mini-USB Type-B Console Port | 93](#)
- [Installing a Transceiver in an NFX150 Device | 94](#)
- [Connecting a Fiber-Optic Cable to an NFX150 Device | 96](#)

Connecting an NFX150 Device to a Network for Out-of-Band Management

Ensure that you have an appropriate cable available.

You can monitor and manage the NFX150 device using a dedicated management channel. NFX150 devices have one management port, eight 1-Gigabit Ethernet RJ-45 ports, two 1-Gigabit Ethernet RJ-45 network/uplink ports, two 1-Gigabit Ethernet small form-factor pluggable (SFP) ports, and two 1/10-

Gigabit Ethernet SFP+ ports. Use the management port to connect the NFX150 device to a network for out-of-band management.

To connect an NFX150 device to a network for out-of-band management (see [Figure 35 on page 91](#)):

1. Connect one end of the cable to the management port (labeled **MGMT**) on the NFX150 device.
2. Connect the other end of the cable to the management switch (see [Figure 35 on page 91](#)).

Figure 35: Connecting an NFX150 Device to a Network for Out-of-Band Management

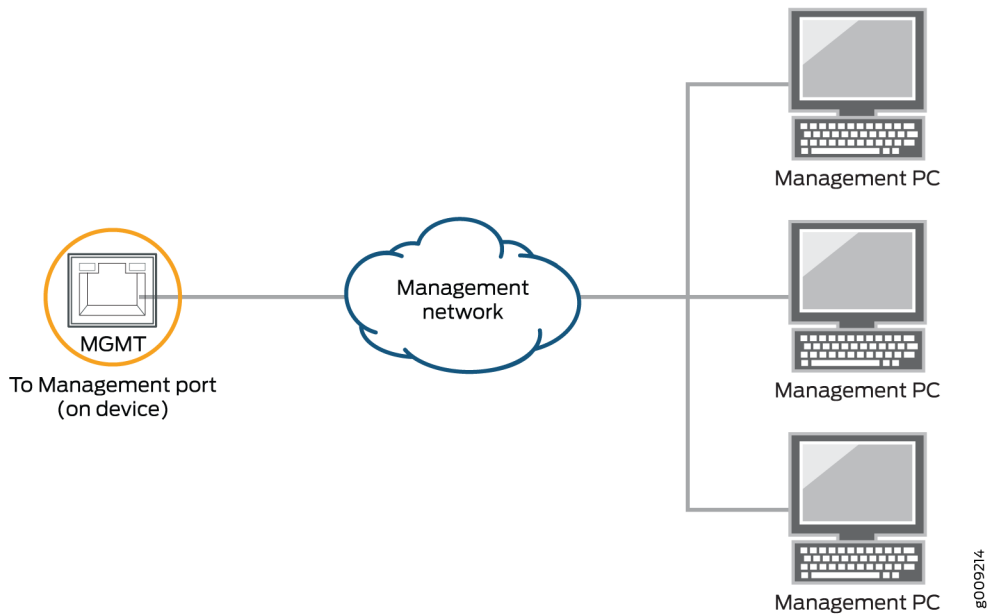

SEE ALSO

[NFX150 Chassis | 10](#)

Connecting an NFX150 Device to a Management Console

Ensure that you have an RJ-45 to DB-9 rollover cable available.

NOTE: We no longer include the console cable as part of the device package. If the console cable and adapter are not included in your device package, or if you need a different type of adapter, you can order the following separately:

- RJ-45 to DB-9 adapter (JNP-CBL-RJ45-DB9)
- RJ-45 to USB-A adapter (JNP-CBL-RJ45-USBA)
- RJ-45 to USB-C adapter (JNP-CBL-RJ45-USBC)

If you want to use RJ-45 to USB-A or RJ-45 to USB-C adapter you must have X64 (64-Bit) Virtual COM port (VCP) driver installed on your PC. See, <https://ftdichip.com/drivers/vcp-drivers/> to download the driver.

NOTE: If your laptop or PC does not have a DB-9 plug connector pin and you want to connect your laptop or PC directly to the NFX150 device, use a combination of the RJ-45 cable and RJ-45 to DB-9 adapter supplied with the device and a USB to DB-9 plug adapter. You must provide the USB to DB-9 plug adapter.

NFX150 device has a console port with an RJ-45 connector. Use the console port to connect the device to a management console or to a console server.

To connect the NFX150 device to a management console (see [Figure 36 on page 92](#) and [Figure 37 on page 93](#)):

1. Connect one end of the Ethernet cable to the console port (labeled **CON**).
2. Connect the other end of the Ethernet cable into the console server (see [Figure 36 on page 92](#)) or management console (see [Figure 37 on page 93](#)).

Figure 36: Connecting the NFX150 Device to a Management Console Through a Console Server

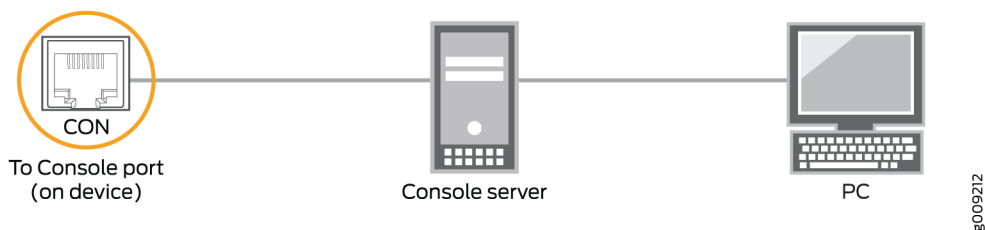

Figure 37: Connecting the NFX150 Device Directly to a Management Console



SEE ALSO

| [Console Port Connector Pinouts for NFX150 Devices](#) | 62

Connecting an NFX150 Device to a Management Console Using Mini-USB Type-B Console Port

Before you begin connecting an NFX150 device by using the Mini-USB Type-B console port:

- Ensure that the USB to Serial driver is installed on the host machine. You can download the driver from <https://webdownload.juniper.net/swdl/dl/secure/site/1/record/5029.html>
- Ensure that the hyper terminal properties of the console server or laptop are set as follows:
 - Baud rate—9600
 - Flow control—None
 - Data—8
 - Parity—None
 - Stop bits—1
 - DCD state—Disregard

Ensure that you have the following parts and tools available:

- 1 mini-USB cable with Standard-A and Mini-USB Type- B (5-pin) connectors (not provided).

You can configure and manage NFX150 devices by using the RJ-45 console port or the Mini-USB Type-B console port. However, the console input will be active only on one port at a time—only one port will be set active at a time.

By default, the RJ-45 port is set as an active console port and the Mini-USB Type-B port is the passive console port.

If your laptop or PC does not have a DB-9 plug connector pin or RJ-45 connector pin, you can connect your laptop or PC directly to an NFX150 device by using a mini-USB cable that has a Standard-A USB connector on one end and a Mini-USB Type-B (5 pin) connector on the other end.

This section describes the process of connecting an NFX150 device to the management console by using the Mini-USB Type-B console port.

For information about configuring and managing an NFX150 device by using the RJ-45 console port, see ["Connecting an NFX150 Device to a Management Console" on page 91](#).

To connect the NFX150 device to the console using Mini-USB Type-B console port:

1. Connect the Standard-A connector of the mini-USB cable to the host machine (PC or Laptop).
2. Connect the Mini-USB Type-B (5-pin) connector of the mini-USB cable to the Mini-USB Type-B console port (labeled **CON**) on the NFX150 device.
3. Set the Mini-USB Type-B console port as the active console port by using the command `port-type`.
4. Reboot the NFX150 device.

After the connection is established, the Mini-USB Type-B becomes the active console port. The host machine connected to the Mini-USB Type-B console port displays log messages and lets you control NFX150 device functionality through it.

Installing a Transceiver in an NFX150 Device

Before you begin installing a transceiver in an NFX150 device, ensure that you have taken the necessary precautions for safe handling of lasers (see ["Laser and LED Safety Guidelines and Warnings for the NFX150 Devices" on page 151](#)).

Ensure that you have a rubber safety cap available to cover the transceiver.

The transceivers for the NFX150 devices are hot-removable and hot-insertable field-replaceable units (FRUs). You can remove and replace them without powering off the device or disrupting device functions.

To install a transceiver in a NFX150 device:



CAUTION: To avoid electrostatic discharge (ESD) damage to the transceiver, do not touch the connector pins at the end of the transceiver.

1. Remove the transceiver from its bag.
2. Check to see whether the transceiver is covered by a rubber safety cap. If it is not, cover the transceiver with a rubber safety cap.



LASER WARNING: Do not leave a fiber-optic transceiver uncovered except when inserting or removing a cable. The rubber safety cap keeps the port clean and prevents accidental exposure to laser light.

3. If the port in which you want to install the transceiver is covered with a dust cover, remove the dust cover and save it in case you need to cover the port later.
4. Using both hands, carefully place the transceiver in the empty port. The connectors must face the device chassis.



CAUTION: Before you slide the transceiver into the port, ensure that the transceiver is aligned correctly. Misalignment might cause the pins to bend, making the transceiver unusable. See [Figure 39 on page 96](#) for the correct orientation for your device.

5. Slide the transceiver in gently until it is fully seated. See [Figure 39 on page 96](#) for an example of inserting an SFP or SFP+ transceiver.
6. Remove the rubber safety cap when you are ready to connect the cable to the transceiver.



LASER WARNING: Do not look directly into a fiber-optic transceiver or into the ends of fiber-optic cables. Fiber-optic transceivers and fiber-optic cables connected to transceivers emit laser light that can damage your eyes.

Figure 38: Installing a Transceiver in an NFX150-S1 Device

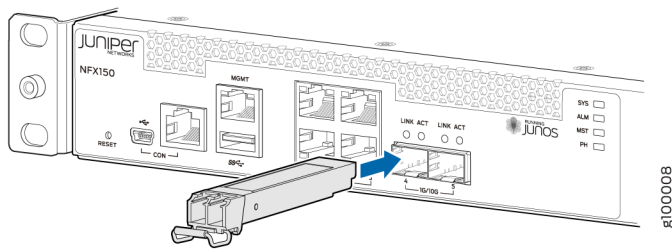
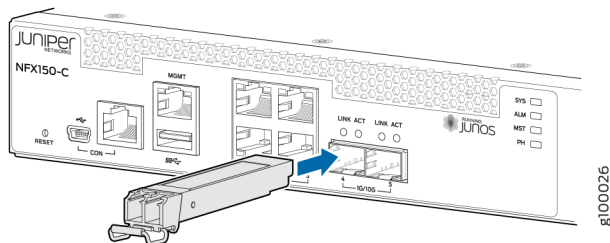

Figure 39: Installing a Transceiver in an NFX150-C-S1 Device



Connecting a Fiber-Optic Cable to an NFX150 Device

Before you connect a fiber-optic cable to an optical transceiver installed in an NFX150 device, ensure that you have taken the necessary precautions for safe handling of lasers (see ["Laser and LED Safety Guidelines and Warnings for the NFX150 Devices"](#) on page 151).

You can connect fiber-optic cables to the field-replaceable unit (FRU) optical transceivers installed in NFX150 devices.

To connect a fiber-optic cable to an optical transceiver installed in an NFX150 device:



LASER WARNING: Do not look directly into a fiber-optic transceiver or into the ends of fiber-optic cables. Fiber-optic transceivers and fiber-optic cables connected to transceivers emit laser light that can damage your eyes.



LASER WARNING: Do not stare into the laser beam or view it directly with optical instruments even if the interface has been disabled.

1. If the fiber-optic cable connector is covered by a rubber safety cap, remove the cap. Save the cap.
2. If the optical transceiver is covered by a rubber safety cap, remove the cap. Save the cap.
3. Insert the cable connector into the optical transceiver (see [Figure 40 on page 97](#)).
4. Secure the cables so that they are not supporting their own weight. Place excess cable out of the way in a neatly coiled loop. Placing fasteners on a loop helps cables maintain their shape.



CAUTION: Do not bend fiber-optic cables beyond their minimum bend radius. Bending the cables beyond their minimum bend radius can damage the cables and cause problems that are difficult to diagnose.



CAUTION: Do not let fiber-optic cables hang free from the connector. Do not allow fastened loops of cables to dangle, which stresses the cables at the fastening point.

Figure 40: Inserting a Fiber-Optic Cable into a Transceiver on an NFX150-S1 Device

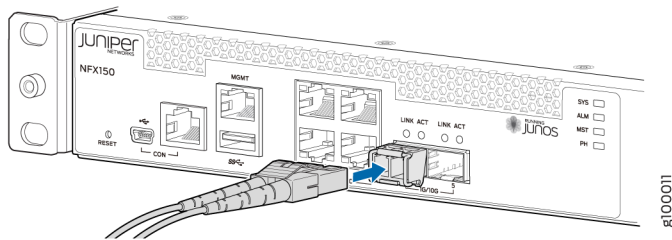
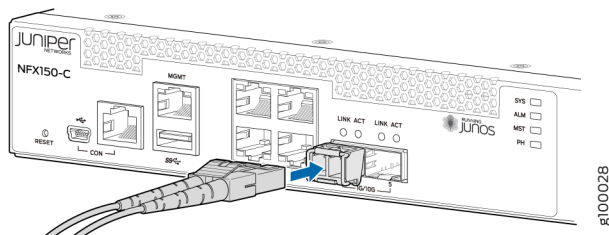

Figure 41: Inserting a Fiber-Optic Cable into a Transceiver on an NFX150-C-S1 Device



Initial Configuration on NFX150 Devices

IN THIS SECTION

- [Factory-Default Settings | 98](#)
- [Enabling Basic Connectivity | 100](#)
- [Establishing the Connection | 102](#)

Factory-Default Settings

The NFX150 device is shipped with the following factory-default settings:

Table 34: Security Policies

Source Zone	Destination Zone	Policy Action
trust	trust	permit
trust	untrust	permit

Table 35: Interface Mapping (for Junos OS Releases 18.1, 18.2 R1, and 18.3 R1)

Port Label	Interface	Virtual Interface	Security Zone	DHCP State	IP Address
0/0 to 0/3	heth-0-0 to heth-0-3	ge-0/0/0 to ge-0/0/3	trust	Server	192.168.2.1/24
0/4	heth-0-4	ge-1/0/1	untrust	Client	ISP assigned
0/5	heth-0-5	ge-1/0/2	untrust	Client	ISP assigned

Table 35: Interface Mapping (for Junos OS Releases 18.1, 18.2 R1, and 18.3 R1) (Continued)

Port Label	Interface	Virtual Interface	Security Zone	DHCP State	IP Address
MGMT	fxp0	N/A	N/A	N/A	192.168.1.1/24

Table 36: Interface Mapping (for Junos OS Releases 18.2 R2 and 18.4R1)

Port Label	Interface	Virtual Interface	Security Zone	DHCP State	IP Address
0/0 to 0/2	heth-0-0 to heth-0-2	ge-0/0/0 to ge-0/0/2	trust	Server	192.168.2.1/24
0/3	heth-0-3	ge-1/0/1	untrust	Client	ISP assigned
0/4	heth-0-4	ge-0/0/3	trust	Server	192.168.2.1/24
0/5	heth-0-5	ge-1/0/2	untrust	Client	ISP assigned
MGMT	fxp0	N/A	N/A	N/A	192.168.1.1/24

Table 37: Interface Mapping (for Junos OS Releases 19.1R1 or later)

Port Label	Interface	Virtual Interface	Security Zone	DHCP State	IP Address
0/0	heth-0-0	ge-1/0/1	untrust	Client	ISP assigned
0/1 to 0/4	heth-0-1 to heth-0-4	ge-0/0/1 to ge-0/0/4	trust	Server	192.168.2.1/24
0/5	heth-0-5	ge-1/0/2	untrust	Client	ISP assigned
MGMT	fxp0	N/A	N/A	N/A	192.168.1.1/24

Table 38: LTE Interfaces

Interface	Security Zone	IP Address
cl-1/1/0	N/A	N/A
dl0 (logical)	untrust	ISP assigned

The NFX150 device is shipped with the following services enabled by default: DHCP, HTTPS, and TFTP.

To provide secure traffic, a basic set of screens are configured on the untrust zone.

Enabling Basic Connectivity

1. Ensure that the NFX150 device is powered on.
2. Connect to the console port:
 - a. Plug one end of the Ethernet cable into the console port on your NFX150 device.
 - b. Connect the other end of the Ethernet cable to the RJ-45-to-DB-9 serial port adapter.
 - c. Connect the RJ-45-to-DB-9 serial port adapter to the serial port on the management device. Use the following values to configure the serial port:
Baud rate—9600; Parity—N; Data bits—8; Stop bits—1; Flow control—None.

NOTE: We no longer include a DB-9 to RJ-45 cable or a DB-9 to RJ-45 adapter with a CAT5E copper cable as part of the device package. If you require a console cable, you can order it separately with the part number JNP-CBL-RJ45-DB9 (DB-9 to RJ-45 adapter with a CAT5E copper cable).

NOTE: Alternately, you can use the USB cable to connect to the mini-USB console port on the device. To use the mini-USB console port, you must download the USB driver from the following page and install it on the management device:

<https://www.juniper.net/support/downloads/junos.html>

3. Use any terminal emulation program, such as HyperTerminal, to connect to the device console. The CLI displays a login prompt.

4. Log in as **root** and enter the password **juniper123**. If the software completes booting before you connect to the console, you might need to press the **Enter** key for the prompt to appear:

NOTE: Starting with Junos OS Release 18.1R2 or later, the root password is not configured for initial configuration of the NFX150 devices.

```
login: root
password: juniper123
```

5. Start the CLI:

```
root@:~ # cli
root@>
```

6. Enter configuration mode:

```
root@> configure
[edit]
root@#
```

7. Change the password for the root administration user account:

```
[edit]
root@# set system root-authentication plain-text-password
New password: password
Retype new password: password
```

8. Enable SSH service for the root user:

```
[edit]
root@# set system services ssh root-login allow
```

9. (Optional) Enable the Internet connection for devices connected on LAN by setting the DNS IP:

```
[edit]
root@# set access address-assignment pool jdhcp-pool family inet dhcp-attributes name-
server dns-server-ip
```

10. Commit the configuration:

```
[edit]
root@# commit
```

Establishing the Connection

1. Connect the device to the Internet Service Provider (ISP) by using the following step:

NOTE: For information on interface mapping, see ["Factory-Default Settings" on page 98](#) and ["Factory-Default Settings" on page 98](#).

Connect one of the WAN ports to the ISP. The device is assigned an IP address by the ISP through DHCP.

Figure 42: Connecting the Interfaces on an NFX150-S1 Device

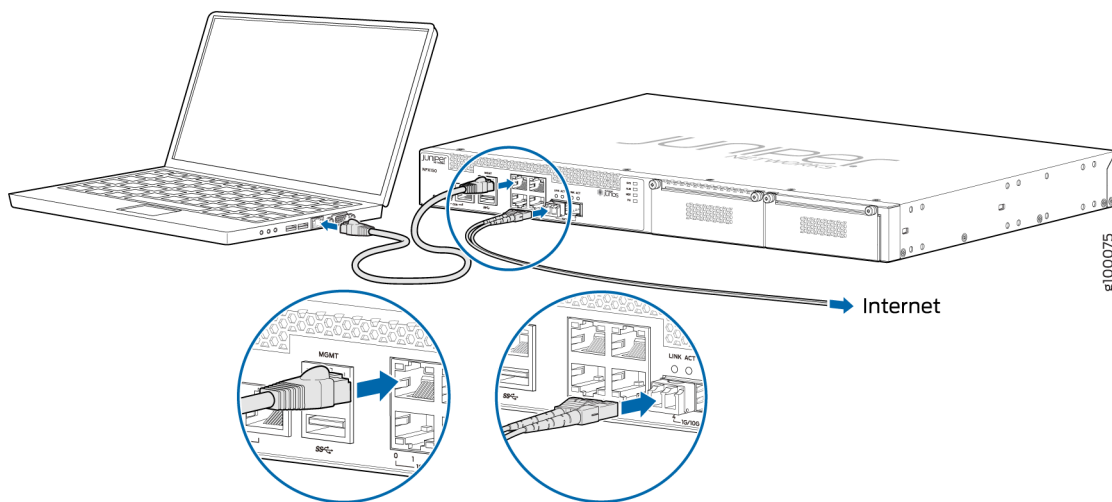

Optionally, you can obtain a SIM card from the ISP and connect the device through LTE.

NOTE: The LTE expansion module must be purchased separately.

2. Connect the laptop to one of the front panel LAN ports. The laptop is assigned an IP address by the DHCP server running on the interface.
3. Open a browser on your laptop, navigate to <https://www.juniper.net>, and verify your connectivity.

RELATED DOCUMENTATION

| [Installing and Configuring the LTE Module](#)

Installing and Configuring the NFX150 Expansion Modules

IN THIS SECTION

- [Installing the Expansion Module | 103](#)
- [Installing the LTE Expansion Module | 104](#)
- [Configuring the LTE Expansion Module | 105](#)
- [Configuring the LTE Expansion Module for Primary Mode | 106](#)
- [Configuring the LTE Expansion Module for Dial-on-Demand Mode | 108](#)
- [Configuring the LTE Expansion Module for Backup Mode | 110](#)
- [Upgrading the Modem Firmware on NFX Devices Through Over-the-Air \(OTA\) | 112](#)

Installing the Expansion Module

NOTE: You can install only one expansion module on the NFX150-S1 devices. The expansion module must be installed in the first slot, which is present beside the chassis LEDs.

To install the expansion module such as NFX-EM-6T2SFP in an NFX150 device:

1. Attach an electrostatic discharge (ESD) grounding strap to your bare wrist, and connect the strap to the grounding point on the back of the device.

2. Power off the device using the following command:

```
request system power-off
```

3. Remove both the blank modules installed on the device:
 - Loosen the screws on the faceplate of the blank module.
 - Grasp the screws on each side and remove the blank module.
4. Remove the expansion module from the electrostatic bag.
5. Grasp the screws on each side of the module faceplate and align the notches in the connector at the rear of the module with the notches in the module slot in the device.
6. Slide the module in until it lodges firmly in the services gateway.
7. Using a 1/8-in. (3-mm) flat-blade (-) screwdriver, tighten the screws on each side of the module faceplate.
8. Power on the device.

Installing the LTE Expansion Module

NOTE: You can install only one expansion module on the NFX150-S1 devices. The expansion module must be installed in the first slot, which is present beside the chassis LEDs.

To install the LTE expansion modules such as NFX-LTE-AE and NFX-LTE-AA in an NFX150 device:

1. Attach an electrostatic discharge (ESD) grounding strap to your bare wrist, and connect the strap to the grounding point on the back of the device.
2. Power off the device using the following command:

```
request system power-off
```

3. Remove both the blank modules installed on the device:
 - Loosen the screws on the faceplate of the blank module.
 - Grasp the screws on each side and remove the blank module.
4. Remove the LTE expansion module from the electrostatic bag.
5. Grasp the screws on each side of the module faceplate and align the notches in the connector at the rear of the module with the notches in the module slot in the device.

6. Slide the module in until it lodges firmly in the services gateway.
7. Using a 1/8-in. (3-mm) flat-blade (-) screwdriver, tighten the screws on each side of the module faceplate.
8. Remove the cover from the SIM slot, SIM 1. Insert the SIM card into the SIM slot. You can use the other slot, SIM 2, for installing a secondary SIM.
9. Replace the cover over the SIM slots.
10. Attach the antennas to the chassis. See [Figure 43 on page 105](#).

Figure 43: Attaching Antennas to the LTE Expansion Module

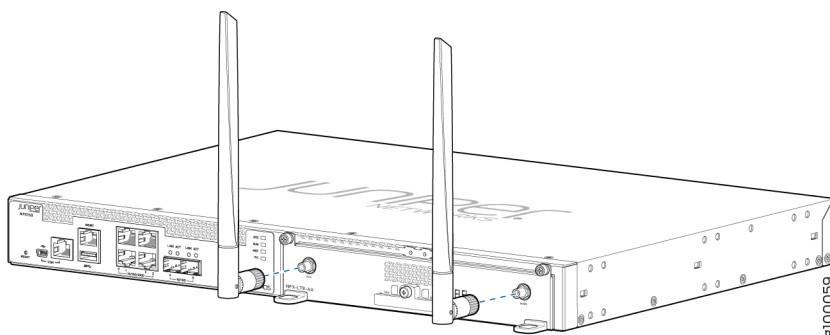

11. Power on the device.

Configuring the LTE Expansion Module

The LTE expansion module can be configured in three modes:

- Always-on—The LTE expansion module connects to the 3G/4G network after booting. The connection is always maintained, as long as there are no network or connectivity problems.

NOTE: The default mode for LTE expansion module is always-on. For the LTE expansion module to be operational, you only need to install one SIM card on the LTE expansion module before powering on the device. There is no additional configuration required.

- Dial-on-demand—The LTE expansion module initiates a connection when it receives interesting traffic. You define interesting traffic using the dialer filter. To configure dial-on-demand using a dialer filter, you first configure the dialer filter and then apply the filter to the dialer interface.

- Backup—The LTE expansion module connects to the 3G/4G network when the primary connection fails.

You can configure the LTE expansion module either as a primary interface or as a backup interface. When configured as the primary interface, the LTE expansion module supports both the always-on and dial-on-demand modes. When configured as the backup interface, the LTE expansion module connects to the network only when the primary interface fails.

Profile configuration is not needed in most scenarios, as LTE has a built-in database of many service providers and can automatically select the profile to use. Occasionally, you might need to specify profiles explicitly in the configuration, in which case, the automatic profile selection is disabled.

Before you begin the configuration, insert the Subscriber Identity Module (SIM) in the LTE expansion module. The SIM uses a profile to establish a connection with the network. You can configure up to 16 profiles for each SIM card. The LTE expansion module supports two SIM cards and so you can configure a total of 32 profiles, although only one profile can be active at a time. To configure the SIM profile, you will require the following information from the service provider:

- Username and password
- Access Point Name (APN)
- Authentication (Challenge Handshake Authentication Protocol (CHAP) or Password Authentication Protocol (PAP))

Configuring the LTE Expansion Module for Primary Mode

Before you begin the procedure, ensure that the logical interface (dl0.0) is not configured as a backup. If dl0.0 is configured as a backup option for any interface on the device, then this configuration overrides the configuration outlined in this procedure, and the LTE expansion module will function as a backup interface.

Use the `show interfaces | display set | match backup-option | match dl0.0` command to check whether any interface uses dl0.0 as a backup interface. If dl0.0 is configured as a backup interface, then delete the configuration by issuing the following command:

```
delete interfaces interface-name unit 0 backup-options interface dl0.0
```

To configure the LTE expansion module as a primary interface:

1. Configure the dialer interface:

```
user@host# set interfaces dl0 unit 0 family inet negotiate-address
user@host# set interfaces dl0 unit 0 family inet6 negotiate-address
```

```

user@host# set interfaces dl0 unit 0 dialer-options pool dialer-pool-number
user@host# set interfaces dl0 unit 0 dialer-options dial-string dial-number
user@host# set interfaces dl0 unit 0 dialer-options always-on

```

2. Configure the dialer pool for the LTE physical interface:

```

user@host# set interfaces cl-1/1/0 dialer-options pool dialer-pool-number

```

NOTE: The *dialer-pool-number* is always 1 as there is only one LTE interface on the NFX150.

3. Configure the profile.

```

user@host# run request modem wireless create-profile profile-id profile-id cl-1/1/0 slot sim-slot-number
access-point-name apn-name authentication-method none

```

NOTE: *sim-slot-number* is the slot on the module in which the SIM card is inserted.

4. Verify that the profile is configured successfully:

```

user@host# run show modem wireless profiles cl-1/1/0 slot 1

```

5. Activate the SIM card:

```

user@host# set interfaces cl-1/1/0 act-sim sim-slot-number

```

6. Select the profile and configure the radio access type for the SIM card:

```

user@host# set interfaces cl-1/1/0 cellular-options sim sim-slot-number select-profile profile-id profile-id
user@host# set interfaces cl-1/1/0 cellular-options sim sim-slot-number radio-access automatic

```

NOTE: If a SIM card is installed in the second slot, then select the profile and configure the radio access type for the SIM card in the second slot as well.

7. Verify the status of the wireless network and dialer interface:

```
user@host# run show modem wireless network
user@host# run show interfaces dl0.0
```

Configuring the LTE Expansion Module for Dial-on-Demand Mode

When the LTE expansion module is configured as a primary interface, it can function either in always-on mode or in dial-on-demand mode. In always-on mode, the interface remains connected to the network whereas in dial-on-demand mode, the connection is established only when needed.

In dial-on-demand mode, the dialer interface is enabled only when network traffic configured as an “interesting traffic” arrives on the network. Interesting traffic triggers or activates the wireless WAN connection. You define an interesting packet by using the dialer filter. To configure dial-on-demand by using a dialer filter, you first configure the dialer filter and then apply the filter to the dialer interface.

Once the traffic is sent over the network, an inactivity timer is triggered and the connection is closed after the timer expires.

NOTE: The dial-on-demand mode is supported only if the LTE expansion module is configured as a primary interface.

To configure the LTE expansion module as a dial-on-demand interface:

1. Configure the dialer interface:

```
user@host# set interfaces dl0 unit 0 family inet negotiate-address
user@host# set interfaces dl0 unit 0 family inet6 negotiate-address
user@host# set interfaces dl0 unit 0 family inet filter dialer dialer-filter-name
user@host# set interfaces dl0 unit 0 dialer-options pool dialer-pool-number
user@host# set interfaces dl0 unit 0 dialer-options dial-string dial-number
```

2. (Optional) Configure the idle-timeout value, which determines the duration for which the connection will remain enabled in the absence of interesting traffic.

```
user@host# set interfaces dl0 unit 0 dialer-options idle-timeout idle-timeout-value
```

3. Configure the dialer pool for the LTE physical interface:

```
user@host# set interfaces cl-1/1/0 dialer-options pool dialer-pool-number
```

NOTE: The *dialer-pool-number* is always 1 as there is only one LTE interface on the NFX150.

4. Create the dialer filter rule:

```
user@host# set firewall family inet dialer-filter dialer-filter-name term term1 from destination-  
address ip-address then note
```

5. Set the default route:

```
set routing-options static route ip-address next-hop dl0.0
```

6. Configure the profile.

```
user@host# run request modem wireless create-profile profile-id profile-id cl-1/1/0 slot sim-slot-  
number access-point-name apn-name authentication-method none
```

NOTE: *sim-slot-number* is the slot on the module in which the SIM card is inserted.

7. Verify that the profile is configured successfully:

```
user@host# run show modem wireless profiles cl-1/1/0 slot 1
```

8. Activate the SIM card:

```
user@host# set interfaces cl-1/1/0 act-sim sim-slot-number
```

9. Select the profile and configure the radio access type for the SIM card:

```
user@host# set interfaces cl-1/1/0 cellular-options sim sim-slot-number select-profile profile-id  
profile-id  
user@host# set interfaces cl-1/1/0 cellular-options sim sim-slot-number radio-access automatic
```

NOTE: If a SIM card is installed in the second slot, then select the profile and configure the radio access type for the SIM card in the second slot as well.

10. Verify the configuration by sending traffic to the destination address. The traffic is routed to the d10 interface and if it matches the dialer filter rule, then the d10 is triggered to dial.
11. Verify the status of the wireless network and dialer interface:

```
user@host# run show modem wireless network
user@host# run show interfaces d10.0
```

Configuring the LTE Expansion Module for Backup Mode

You can configure the LTE expansion module as a backup interface. If the primary interface fails, the LTE expansion module connects to the network and remains online only until the primary interface becomes functional. The dialer interface is enabled only when the primary interface fails.

To configure the LTE expansion module as a backup interface:

1. Configure the dialer interface:

```
user@host# set interfaces d10 unit 0 family inet negotiate-address
user@host# set interfaces d10 unit 0 family inet6 negotiate-address
user@host# set interfaces d10 unit 0 dialer-options pool dialer-pool-number
user@host# set interfaces d10 unit 0 dialer-options dial-string dial-number
```

2. Configure the dialer pool for the LTE physical interface:

```
user@host# set interfaces cl-1/1/0 dialer-options pool dialer-pool-number
```

NOTE: The *dialer-pool-number* is always 1 as there is only one LTE interface on the NFX150.

3. Configure the profile.

```
user@host# run request modem wireless create-profile profile-id profile-id cl-1/1/0 slot sim-slot-number
access-point-name l3vpn.corp authentication-method none
```

NOTE: *sim-slot-number* is the slot on the LTE expansion module in which the SIM card is inserted.

4. Verify that the profile is configured successfully:

```
user@host# run show modem wireless profiles cl-1/1/0 slot 1
```

5. Activate the SIM card:

```
user@host# set interfaces cl-1/1/0 act-sim sim-slot-number
```

6. Select the profile and configure the radio access type for the SIM card:

```
user@host# set interfaces cl-1/1/0 cellular-options sim sim-slot-number select-profile profile-id profile-id
user@host# set interfaces cl-1/1/0 cellular-options sim sim-slot-number radio-access automatic
```

NOTE: If a SIM card is installed in the second slot, then select the profile and configure the radio access type for the SIM card in the second slot as well.

7. Configure the Ethernet interface as the primary interface, which connects to the wireless network. Configure the d10 interface as the backup interface.

```
user@host# set interfaces ge-1/0/2 unit 0 family inet address 192.168.2.1/24
user@host# set interfaces ge-1/0/2 unit 0 backup-options interface d10.0
```

8. Verify the status of the wireless network and dialer interface:

```
user@host# run show modem wireless network
user@host# run show interfaces d10.0
```

Upgrading the Modem Firmware on NFX Devices Through Over-the-Air (OTA)

Over-the-Air (OTA) firmware upgrade enables automatic and timely upgrade of modem firmware when new firmware versions are available. The OTA upgrade can be enabled or disabled on the LTE module. OTA is disabled by default.

NOTE: When upgrading the software on the NFX devices, the LTE firmware is also upgraded if the software contains a newer firmware version.

1. Enable OTA upgrade on the LTE module:

```
user@host > request modem wireless fota cl-1/1/0 enable
```

```
Set FOTA on modem succeeded
```

2. Initiate the firmware upgrade:

```
user@host > request modem wireless upgrade cl-1/1/0
```

```
Launch FOTA upgrade succeeded
```

3. Verify the firmware upgrade status:

```
user@host > show modem wireless firmware cl-1/1/0
```

```
LTE mPIM firmware details
```

```
Product name: Junos LTE mPIM
```

```
Serial number: D23F4349-10FA-41AA-A538-03648DE
```

```
Hardware version: AcceleratedConcepts/porter
```

```
Firmware version: 17.11.13
```

```
MAC: 00:00:5e:00:53:82
```

```
System uptime: 4632 seconds
```

```
Wireless modem firmware details
```

```
Modem firmware version: 9999999_9904609_SWI9X30C_02.24.05.06_00_GENERIC_002.026_000
```

```
Modem Firmware build date: 19/05/2017
```

```
Card type: MC7455
```

```
Modem manufacturer: Sierra Wireless, Inc
```

```
Hardware version: 1.0
```

```
Power & Temperature: Normal 3368 mV, Normal 29.00 C
```

```
OTA status
```



```
State: Enabled
New firmware available: No
Number of SIM: 1
Slot of active: 1
Status of SIM 1
SIM state: SIM present
Modem PIN security status: Disabled
SIM status: SIM Okay
SIM user operation needed: No Op
Retries remaining: 3
```

4. Check the LTE module connection status:

```
user@host > show modem wireless network cl-1/1/0
```

```
LTE Connection details
Connected time: 2880
IP: 10.12.219.210
Gateway: 10.12.219.209
DNS: 123.123.123.123
IPv6: ::
Gatewayv6: ::
DNSv6: ::
Input bps: 0
Output bps: 0
Bytes Received: 1952
Bytes Transferred: 2164
Packets Received: 10
Packets Transferred: 20
Wireless Modem Network Info
Current Modem Status: Connected
Current Service Status: Normal
Current Service Type: PS
Current Service Mode: LTE
Current Band: B3
Network: UNICOM
Mobile Country Code (MCC): 460
Mobile Network Code (MNC): 1
Location Area Code (LAC): 65534
Routing Area Code (RAC): 0
Cell Identification: 239907605
Access Point Name (APN): 3gnet
```

```
Public Land Mobile Network (PLMN): CHN-UNICOM
Physical Cell ID (PCI): 452
International Mobile Subscriber Identification (IMSI): *****
International Mobile Equipment Identification (IMEI/MEID): *****
Integrate Circuit Card Identity (ICCID): 89860117811046631207
Reference Signal Receiving Power (RSRP): -71
Reference Signal Receiving Quality (RSRQ): -8
Signal to Interference-plus-Noise Ratio (SiNR): 19
Signal Noise Ratio (SNR): 22
Energy per Chip to Interference (ECIO): 0
```

SEE ALSO

| *Configuring the LTE Module on NFX Devices*

4

CHAPTER

Maintaining Components

Maintaining Transceivers on the NFX150 | 116

Maintaining Fiber-Optic Cables on the NFX150 | 120

Removing the NFX150 Device from a Rack or Cabinet | 123

Maintaining Transceivers on the NFX150

IN THIS SECTION

- [Installing a Transceiver in an NFX150 Device | 116](#)
- [Removing a Transceiver from an NFX150 Device | 118](#)

Installing a Transceiver in an NFX150 Device

Before you begin installing a transceiver in an NFX150 device, ensure that you have taken the necessary precautions for safe handling of lasers (see "[Laser and LED Safety Guidelines and Warnings for the NFX150 Devices](#)" on page 151).

Ensure that you have a rubber safety cap available to cover the transceiver.

The transceivers for the NFX150 devices are hot-removable and hot-insertable field-replaceable units (FRUs). You can remove and replace them without powering off the device or disrupting device functions.

To install a transceiver in a NFX150 device:



CAUTION: To avoid electrostatic discharge (ESD) damage to the transceiver, do not touch the connector pins at the end of the transceiver.

1. Remove the transceiver from its bag.
2. Check to see whether the transceiver is covered by a rubber safety cap. If it is not, cover the transceiver with a rubber safety cap.



LASER WARNING: Do not leave a fiber-optic transceiver uncovered except when inserting or removing a cable. The rubber safety cap keeps the port clean and prevents accidental exposure to laser light.

3. If the port in which you want to install the transceiver is covered with a dust cover, remove the dust cover and save it in case you need to cover the port later.

- Using both hands, carefully place the transceiver in the empty port. The connectors must face the device chassis.



CAUTION: Before you slide the transceiver into the port, ensure that the transceiver is aligned correctly. Misalignment might cause the pins to bend, making the transceiver unusable. See [Figure 45 on page 117](#) for the correct orientation for your device.

- Slide the transceiver in gently until it is fully seated. See [Figure 45 on page 117](#) for an example of inserting an SFP or SFP+ transceiver.
- Remove the rubber safety cap when you are ready to connect the cable to the transceiver.



LASER WARNING: Do not look directly into a fiber-optic transceiver or into the ends of fiber-optic cables. Fiber-optic transceivers and fiber-optic cables connected to transceivers emit laser light that can damage your eyes.

Figure 44: Installing a Transceiver in an NFX150-S1 Device

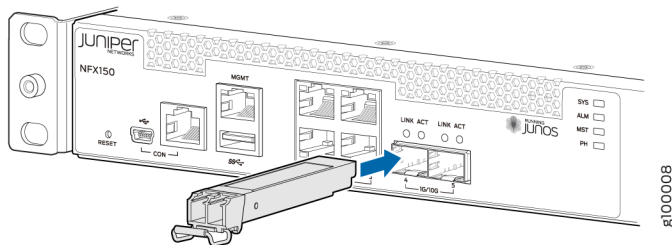
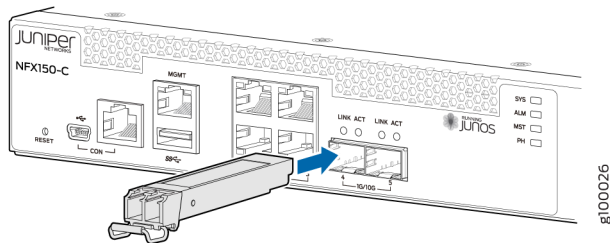

Figure 45: Installing a Transceiver in an NFX150-C-S1 Device



Removing a Transceiver from an NFX150 Device

Before you begin removing a transceiver from the NFX150 device, ensure that you have taken the necessary precautions for safe handling of lasers (see "[Laser and LED Safety Guidelines and Warnings for the NFX150 Devices](#)" on page 151).

Ensure that you have the following parts and tools available:

- Electrostatic bag or an antistatic mat
- Rubber safety caps to cover the transceiver and fiber-optic cable connector
- Dust cover to cover the port

The transceivers for the NFX150 devices are hot-removable and hot-insertable field-replaceable units (FRUs). You can remove and replace them without powering off the device or disrupting device functions.

To remove a transceiver from the NFX150 device:

1. Place the antistatic bag or antistatic mat on a flat, stable surface.
2. Label the cable connected to the transceiver so that you can reconnect it correctly.



LASER WARNING: Do not look directly into a fiber-optic transceiver or into the ends of fiber-optic cables. Fiber-optic transceivers and fiber-optic cables connected to transceivers emit laser light that can damage your eyes.



LASER WARNING: Do not leave a fiber-optic transceiver uncovered except when inserting or removing a cable. The rubber safety cap keeps the port clean and prevents accidental exposure to laser light.



CAUTION: Do not bend fiber-optic cables beyond their minimum bend radius. Bending the cables beyond their minimum bend radius can damage the cables and cause problems that are difficult to diagnose.

3. Remove the cable connected to the transceiver (see "[Disconnecting a Fiber-Optic Cable from an NFX150 Device](#)" on page 121). Cover the transceiver and the end of each fiber-optic cable connector with a rubber safety cap immediately after disconnecting the fiber-optic cables.
4. Using your fingers, pull the ejector lever away from the transceiver to unlock the transceiver.



CAUTION: Before removing the transceiver, make sure you open the ejector lever completely until you hear it click. This prevents damage to the transceiver.

5. Grasp the transceiver ejector lever and gently slide the transceiver approximately 0.5 in. (1.3 cm) straight out of the port (see [Figure 47 on page 119](#)).



CAUTION: To avoid electrostatic discharge (ESD) damage to the transceiver, do not touch the connector pins at the end of the transceiver.

6. Using your fingers, grasp the body of the transceiver and pull it straight out of the port.
7. Place the transceiver in the electrostatic bag or on the antistatic mat placed on a flat, stable surface.
8. Place the dust cover over the empty port.

Figure 46: Removing a Transceiver from an NFX150-S1 Device

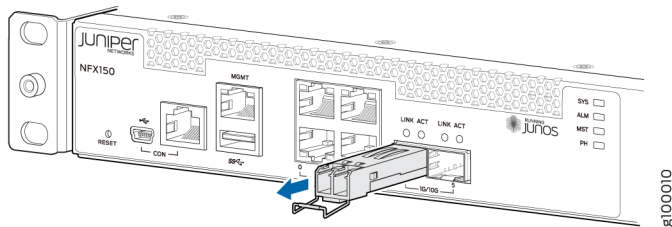
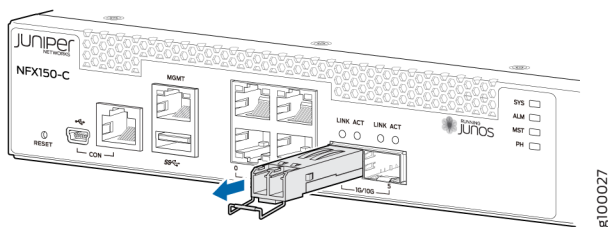

Figure 47: Removing a Transceiver from an NFX150-C-S1 Device



SEE ALSO

| [Installing a Transceiver in an NFX150 Device | 94](#)

Maintaining Fiber-Optic Cables on the NFX150

IN THIS SECTION

- [Maintaining Fiber-Optic Cables in an NFX150 Device | 120](#)
- [Disconnecting a Fiber-Optic Cable from an NFX150 Device | 121](#)
- [Connecting a Fiber-Optic Cable to an NFX150 Device | 122](#)

Maintaining Fiber-Optic Cables in an NFX150 Device

To maintain fiber-optic cables in NFX150 devices:

- When you unplug a fiber-optic cable from a transceiver, place rubber safety caps over the transceiver and on the end of the cable.
- Anchor fiber-optic cable to avoid stress on the connectors. When attaching a fiber-optic cable to a transceiver, be sure to secure the fiber-optic cable so that it is not supporting its own weight as it hangs to the floor. Never let a fiber-optic cable hang free from the connector.
- Do not bend fiber-optic cables beyond their minimum bend radius. Bending the cables beyond their minimum bend radius can damage the cables and cause problems that are difficult to diagnose.
- Frequent plugging and unplugging of fiber-optic cables in and out of optical instruments can damage the instruments, which are expensive to repair. Attach a short fiber extension to the optical equipment. Any wear and tear due to frequent plugging and unplugging is then absorbed by the short fiber extension, which is easier and less expensive to replace than the instruments.
- Keep fiber-optic cable connections clean. Microdeposits of oil and dust in the canal of the transceiver or cable connector can cause loss of light, reduction in signal power, and possibly intermittent problems with the optical connection.

To clean the transceiver canal, use an appropriate fiber-cleaning device such as RIFOCS Fiber Optic Adaptor Cleaning Wands (part number 946). Follow the directions in the cleaning kit you use.

After cleaning the transceiver, make sure that the connector tip of the fiber-optic cable is clean. Use only an approved alcohol-free fiber-optic cable cleaning kit such as the Cletop-S® Fiber Cleaner. Follow the directions in the cleaning kit you use.

Disconnecting a Fiber-Optic Cable from an NFX150 Device

Before you disconnect a fiber-optic cable from an optical transceiver installed in an NFX150 device, ensure that you have taken the necessary precautions for safe handling of lasers (see "[Laser and LED Safety Guidelines and Warnings for the NFX150 Devices](#)" on page 151).

Ensure that you have the following parts and tools available:

- Rubber safety cap to cover the transceiver
- Rubber safety cap to cover the fiber-optic cable connector

To disconnect a fiber-optic cable from an optical transceiver installed in the NFX150 device:

1. (Recommended) Disable the port in which the transceiver is installed by including the disable statement at the [edit interfaces] hierarchy level for the specific interface.



LASER WARNING: Do not look directly into a fiber-optic transceiver or into the ends of fiber-optic cables. Fiber-optic transceivers and fiber-optic cables connected to transceivers emit laser light that can damage your eyes.



LASER WARNING: Do not stare into the laser beam or view it directly with optical instruments even if the interface has been disabled.

2. Carefully unplug the fiber-optic cable connector from the transceiver.
3. Cover the transceiver with a rubber safety cap.



LASER WARNING: Do not leave a fiber-optic transceiver uncovered except when inserting or removing a cable. The rubber safety cap keeps the port clean and prevents accidental exposure to laser light.

4. Cover the fiber-optic cable connector with the rubber safety cap.

SEE ALSO

| [Installing a Transceiver in an NFX150 Device](#) | 94

Connecting a Fiber-Optic Cable to an NFX150 Device

Before you connect a fiber-optic cable to an optical transceiver installed in an NFX150 device, ensure that you have taken the necessary precautions for safe handling of lasers (see "[Laser and LED Safety Guidelines and Warnings for the NFX150 Devices](#)" on page 151).

You can connect fiber-optic cables to the field-replaceable unit (FRU) optical transceivers installed in NFX150 devices.

To connect a fiber-optic cable to an optical transceiver installed in an NFX150 device:



LASER WARNING: Do not look directly into a fiber-optic transceiver or into the ends of fiber-optic cables. Fiber-optic transceivers and fiber-optic cables connected to transceivers emit laser light that can damage your eyes.



LASER WARNING: Do not stare into the laser beam or view it directly with optical instruments even if the interface has been disabled.

1. If the fiber-optic cable connector is covered by a rubber safety cap, remove the cap. Save the cap.
2. If the optical transceiver is covered by a rubber safety cap, remove the cap. Save the cap.
3. Insert the cable connector into the optical transceiver (see [Figure 48 on page 123](#)).
4. Secure the cables so that they are not supporting their own weight. Place excess cable out of the way in a neatly coiled loop. Placing fasteners on a loop helps cables maintain their shape.



CAUTION: Do not bend fiber-optic cables beyond their minimum bend radius. Bending the cables beyond their minimum bend radius can damage the cables and cause problems that are difficult to diagnose.



CAUTION: Do not let fiber-optic cables hang free from the connector. Do not allow fastened loops of cables to dangle, which stresses the cables at the fastening point.

Figure 48: Inserting a Fiber-Optic Cable into a Transceiver on an NFX150-S1 Device

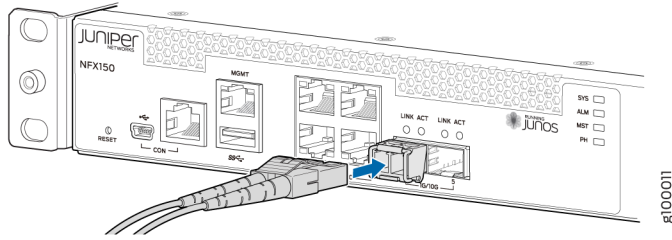
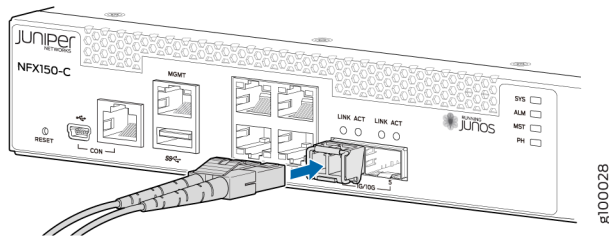

Figure 49: Inserting a Fiber-Optic Cable into a Transceiver on an NFX150-C-S1 Device



Removing the NFX150 Device from a Rack or Cabinet

IN THIS SECTION

- [Powering off an NFX150 Device | 123](#)
- [Removing an NFX150 Device from a Rack or Cabinet | 125](#)

Powering off an NFX150 Device

To power off the NFX150 device, follow the procedure in this topic.

Before you power off the switch:

- Ensure that you understand how to prevent electrostatic discharge damage. See [Prevention of Electrostatic Discharge Damage](#).
- Ensure that you do not need to forward traffic through the device.

Ensure that you have the following parts and tools available to power off the switch:

- An electrostatic discharge (ESD) grounding strap
- An external management device such as a PC
- A cable to connect the external management device to the console port (CON) or management port (MGMT) on the device

To power off the device:

1. Connect the management device (such as a PC) to the console (CON) port or the management (MGMT) port on the device:
 - For connecting a management device to the console port, see ["Connecting an NFX150 Device to a Management Console" on page 91](#).
 - For connecting a management device to the management port, see ["Connecting an NFX150 Device to a Network for Out-of-Band Management" on page 90](#)
2. From the PC connected to the device, issue the following operational mode CLI command:
user@switch> **request vmhost halt**

This command shuts down the device gracefully and preserves system state information. A message displays on the console confirming that the operating system has halted.

You will see the following output (or something similar, depending on the hardware being shut down):

```
user@switch> request vmhost halt
warning: This command will halt all the members.
If planning to halt only one member use the member option
Halt the system ? [yes,no] (no) yes

*** FINAL System shutdown message from user@switch ***
System going down IMMEDIATELY

Shutdown NOW!
[pid 14102]
message sent

{master:0}
user@switch> Waiting (max 300 seconds) for system process `vnlru' to stop...done
```

```

Waiting (max 300 seconds) for system process `vnlru_mem' to stop...done
Waiting (max 300 seconds) for system process `bufdaemon' to stop...done
Waiting (max 300 seconds) for system process `syncer' to stop...
Syncing disks, vnodes remaining...3 3 1 2 2 0 0 0 done

```

```

syncing disks... All buffers synced.
Uptime: 38d18h0m6s
recorded reboot as normal shutdown

```

```

The operating system has halted.
Please press any key to reboot

```



CAUTION: The final output of any version of this command is the The operating system has halted. Please press any key to reboot. message. Wait for at least 60 seconds after seeing this message and before following the instructions in Steps 3 and 4 to power off the device.



CAUTION: Ensure that you have halted your system safely before turning off the power supply.

3. Wrap and fasten one end of the ESD grounding strap around your wrist and connect the other end to a site ESD point.
4. Set the power switch to OFF (O) position.

SEE ALSO

| [Connecting AC Power to an NFX150 Device | 88](#)

Removing an NFX150 Device from a Rack or Cabinet

Before removing the device from a rack:

Ensure that you have the following parts and tools available to remove the device:

- A Phillips (+) screwdriver, number 2 or number 3, depending on the size of your rack mounting screws.
- A labeled bag to hold the removed screws.

If you need to relocate an installed NFX150 device, use the procedure described in this topic. (The remainder of this topic uses *rack* to mean *rack or cabinet*.)

NOTE: When you remove multiple devices from a rack, remove the device at the top of the rack first and proceed to remove the rest of the devices from top to bottom.



CAUTION: At least two people must be available to lift a device chassis out of a rack—one person to unscrew the mounting screws from the brackets and the second person to hold the chassis.

- Ensure that the rack or cabinet is stable and secured to the building.
- Ensure that there is enough space to place the removed device in its new location and along the path to the new location.
- Read [General Safety Guidelines and Warnings](#), with particular attention to "[Chassis Lifting Guidelines for NFX150 Devices](#)" on page 145.
- Ensure that the device has been safely powered off and that you have unplugged (disconnected) the power cords.
- Ensure that you have disconnected any cables or wires attached to the device.

To remove an NFX150 device from a rack:

1. Use the appropriate Phillips (+) screwdriver to remove the mounting screws that attach the chassis front-mounting brackets to the rack.
2. Place the removed screws in a labeled bag. You will need them when you reinstall the chassis.
3. Lift the chassis from the rack and carefully move the chassis to its new location.

SEE ALSO

[General Safety Guidelines and Warnings](#) | 139

[Chassis Lifting Guidelines for NFX150 Devices](#) | 145

5

CHAPTER

Troubleshooting Hardware

[Understanding Alarm Types and Severity Levels on NFX150 Devices](#) | 128

Understanding Alarm Types and Severity Levels on NFX150 Devices

Alarms alert you to conditions that might prevent normal operation of the NFX150 device. [Table 39 on page 128](#) provides a list of alarm terms and definitions that may help you in monitoring the device.

Table 39: Alarm Terms and Definitions

Term	Definition
Alarm	Signal alerting you to conditions that might prevent normal operation. LEDs are the alarm indicators on the device. Blinking amber LEDs indicate yellow alarm conditions for chassis components.
Alarm condition	Failure event that triggers an alarm.
Alarm severity levels	<p>Seriousness of the alarm. The level of severity can be either major (red) or minor (yellow).</p> <ul style="list-style-type: none"> • Major (red)—Indicates a critical situation on the device that has resulted from one of the following conditions. A red alarm condition requires immediate action. <ul style="list-style-type: none"> • One or more hardware components have failed. • One or more hardware components have exceeded temperature thresholds. • An alarm condition configured on an interface has triggered a critical warning. • Minor (yellow or amber)—Indicates a noncritical condition on the device that, if left unchecked, might cause an interruption in service or degradation in performance. A yellow alarm condition requires monitoring or maintenance. For example, a missing rescue configuration generates a yellow system alarm.

Table 39: Alarm Terms and Definitions (Continued)

Term	Definition
Alarm types	<p>Alarms include the following types:</p> <ul style="list-style-type: none">• Chassis alarm—Predefined alarm triggered by a physical condition on the device such as a power supply failure or excessive component temperature.• Interface alarm—Alarm you configure to alert you when an interface link is down. Applies to ethernet, fibre-channel, and management-ethernet interfaces. You can configure a red (major) or yellow (minor) alarm for the link-down condition, or have the condition ignored.• System alarm—Predefined alarm that might be triggered by a missing rescue configuration, failure to install a license for a licensed software feature, or high disk usage.

RELATED DOCUMENTATION

[NFX150 Network Services Platform Overview | 2](#)



CHAPTER

Contacting Customer Support and Returning the Chassis or Components

[Returning the NFX150 Chassis or Components](#) | 131

Returning the NFX150 Chassis or Components

IN THIS SECTION

- [Returning a NFX150 Device or Component for Repair or Replacement | 131](#)
- [Locating the Serial Number on an NFX150 Device | 132](#)
- [Contacting Customer Support to Obtain a Return Materials Authorization for an NFX150 Device | 133](#)
- [Packing an NFX150 Device or Component for Shipping | 135](#)

Returning a NFX150 Device or Component for Repair or Replacement

If you need to return a NFX150 device or component to Juniper Networks for repair or replacement, follow this procedure:

1. Determine the serial number of the device or component. For instructions, see "[Locating the Serial Number on an NFX150 Device](#)" on page 132.
2. Obtain a Return Materials Authorization (RMA) number from the Juniper Technical Assistance Center (JTAC) as described in "[Contacting Customer Support to Obtain a Return Materials Authorization for an NFX150 Device](#)" on page 133.

NOTE: Do not return any device or component to Juniper Networks unless you have first obtained an RMA number. Juniper Networks reserves the right to refuse shipments that do not have an RMA. Refused shipments are returned to the customer through collect freight.

3. Pack the NFX150 device or component for shipping as described in "[Packing an NFX150 Device or Component for Shipping](#)" on page 135.

For more information about return and repair policies, see the customer support page at <https://www.juniper.net/support/guidelines.html>.

SEE ALSO

[NFX150 Network Services Platform Overview | 2](#)

Locating the Serial Number on an NFX150 Device

IN THIS SECTION

- [Listing the Device and Components Details with the CLI | 132](#)
- [Locating the Chassis Serial Number ID Label on an NFX150 Device | 133](#)

If you are returning a device to Juniper Networks for repair or replacement, you must locate the serial number of the device. You must provide the serial number to the Juniper Networks Technical Assistance Center (JTAC) when you contact them to obtain Return Materials Authorization (RMA).

If the device is operational and you can access the CLI, you can list serial numbers for the device with a CLI command.

Listing the Device and Components Details with the CLI

To list the device and device components and their serial numbers, enter the following CLI command:

The following output lists the device components and serial numbers for a NFX150 device:

```
user@host> show chassis hardware
Hardware inventory:
Item          Version  Part number  Serial number  Description
CChassis                               D
Pseudo CB 0
Routing Engine 0          BUILTIN  BUILTIN        RE-NFX150-ATT-S2
FPC 0                REV 02   650-065559    DC4115AN0025
  CPU                BUILTIN  BUILTIN        FPC CPU
  PIC 0              REV 02   BUILTIN        BUILTIN        10x10/100/1000 Base-T-2x1G SFP-
    Xcvr 12           REV 01   740-031980    ARN2FUA        SFP+-10G-SR
    Xcvr 13           REV 01   740-031980    AN40MW2        SFP+-10G-SR
Power Supply 0
Fan Tray 0                fan-ctrl-0 0, Front to Back Airflow -
AFO
Fan Tray 1                fan-ctrl-0 1, Front to Back Airflow -
AFO
```

To view the details of the expansion module, you must use the `show system inventory hardware expansion-module` command.

```
user@host> show system inventory hardware expansion-module

Expansion module information:
Serial Module type number Revision Part number CLEI code Description
NFX-EM-6T2SFP EA3417AF0004 REV 02 611-075433 CSUIAB2GAAN Expansion Module for 6 Copper and 2 SFP
```

For information about the `show chassis hardware` command, see the *Junos OS System Basics and Services Command Reference* at <https://www.juniper.net/documentation/software/junos/index.html>.

Locating the Chassis Serial Number ID Label on an NFX150 Device

The serial number ID label is located on the back of the chassis on an NFX150 device. See Figure 1.

Figure 50: Location of the Serial Number ID Label on an NFX150 Device

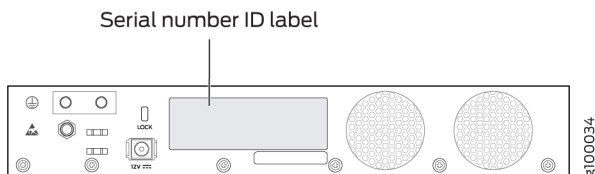

RELATED DOCUMENTATION

[Contacting Customer Support to Obtain a Return Materials Authorization for an NFX150 Device | 133](#)

Contacting Customer Support to Obtain a Return Materials Authorization for an NFX150 Device

If you are returning a NFX150 device or component to Juniper Networks for repair or replacement, obtain a Return Materials Authorization (RMA) from the Juniper Networks Technical Assistance Center (JTAC).

After locating the serial number of the device or component you want to return, open a service request with Juniper Networks Technical Assistance Center (JTAC) on the Web or by telephone.

For instructions on locating the serial number of the device or component you want to return, see ["Locating the Serial Number on an NFX150 Device" on page 132](#).

Before you request an RMA from JTAC, be prepared to provide the following information:

- Your existing service request number, if you have one
- Serial number of the component
- Your name, organization name, telephone number, fax number, and shipping address
- Details of the failure or problem
- Type of activity being performed on the device when the problem occurred
- Configuration data displayed by one or more `show` commands

You can contact JTAC 24 hours a day, seven days a week on the Web or by telephone:

- Service Request Manager: <https://support.juniper.net/support>
- Telephone: +1-888-314-JTAC (+1-888-314-5822), toll-free in the USA, Canada, and Mexico

NOTE: For international or direct-dial options in countries without toll-free numbers, see <https://support.juniper.net/support>.

If you are contacting JTAC by telephone, enter your 12-digit service request number followed by the pound (#) key for an existing case, or press the star (*) key to be routed to the next available support engineer.

The support representative validates your request and issues an RMA number for return of the component.

SEE ALSO

| [Returning a NFX150 Device or Component for Repair or Replacement](#) | 131

Packing an NFX150 Device or Component for Shipping

IN THIS SECTION

- [Packing a NFX150 Device for Shipping | 135](#)
- [Packing NFX150 Device Components for Shipping | 136](#)

If you are returning a NFX150 device or component to Juniper Networks for repair or replacement, pack the item as described in this topic.

Before you pack a NFX150 device or component:

- Ensure that you have taken the necessary precautions to prevent electrostatic discharge (ESD) damage. See [Prevention of Electrostatic Discharge Damage](#).
- Retrieve the original shipping carton and packing materials. Contact your JTAC representative if you do not have these materials, to learn about approved packing materials. See ["Contacting Customer Support to Obtain a Return Materials Authorization for an NFX150 Device" on page 133](#).

Ensure that you have the following parts and tools available:

- ESD grounding strap.
- Antistatic bag, one for each component.
- If you are returning the chassis, an appropriate screwdriver for the mounting screws used on your rack or cabinet.

This topic describes:

Packing a NFX150 Device for Shipping

To pack a NFX150 device for shipping:

1. Power down the NFX150 device and remove the power cables. See ["Powering off an NFX150 Device" on page 123](#)
2. Remove the cables that connect the device to all external devices.
3. Remove all field-replaceable units (FRUs) from the NFX150 device.
4. Have one person support the weight of the device while another person unscrews and removes the mounting screws.

5. Remove the device from the rack or cabinet (see ["Chassis Lifting Guidelines for NFX150 Devices" on page 145](#)) and place the device in an antistatic bag.
6. Place the device in the shipping carton.
7. Place the packing foam on top and around the device.
8. If you are returning accessories or FRUs with the device, pack them as instructed in ["Packing an NFX150 Device or Component for Shipping" on page 135](#).
9. Replace the accessory box on top of the packing foam.
10. Close the top of the cardboard shipping box and seal it with packing tape.
11. Write the RMA number on the exterior of the box to ensure proper tracking.

Packing NFX150 Device Components for Shipping



CAUTION: Do not stack the NFX150 device components. Return individual components in separate boxes if they do not fit together on one level in the shipping box.

To pack and ship NFX150 device components:

- Place individual FRUs in antistatic bags.
- Ensure that the components are adequately protected with packing materials and packed so that the pieces are prevented from moving around inside the carton.
- Close the top of the cardboard shipping box and seal it with packing tape.
- Write the RMA number on the exterior of the box to ensure proper tracking.

RELATED DOCUMENTATION

[Returning a NFX150 Device or Component for Repair or Replacement](#) | 131

7

CHAPTER

Safety and Compliance Information

- General Safety Guidelines and Warnings | 139
- Definitions of Safety Warning Levels | 140
- Qualified Personnel Warning | 142
- Warning Statement for Norway and Sweden | 142
- Fire Safety Requirements | 143
- Installation Instructions Warning | 144
- Chassis Lifting Guidelines for NFX150 Devices | 145
- Restricted Access Warning | 145
- Ramp Warning | 146
- Rack-Mounting and Cabinet-Mounting Warnings | 147
- Laser and LED Safety Guidelines and Warnings for the NFX150 Devices | 151
- Radiation from Open Port Apertures Warning | 157
- Maintenance and Operational Safety Guidelines and Warnings | 158
- General Electrical Safety Guidelines and Warnings | 163
- Action to Take After an Electrical Accident | 165
- Prevention of Electrostatic Discharge Damage | 165
- AC Power Electrical Safety Guidelines | 167
- AC Power Disconnection Warning | 168
- TN Power Warning | 169
- Agency Approvals for NFX150 Devices | 170

General Safety Guidelines and Warnings

The following guidelines help ensure your safety and protect the device from damage. The list of guidelines might not address all potentially hazardous situations in your working environment, so be alert and exercise good judgment at all times.

- Perform only the procedures explicitly described in the hardware documentation for this device. Make sure that only authorized service personnel perform other system services.
- Keep the area around the device clear and free from dust before, during, and after installation.
- Keep tools away from areas where people could trip over them while walking.
- Do not wear loose clothing or jewelry, such as rings, bracelets, or chains, which could become caught in the device.
- Wear safety glasses if you are working under any conditions that could be hazardous to your eyes.
- Do not perform any actions that create a potential hazard to people or make the equipment unsafe.
- Never attempt to lift an object that is too heavy for one person to handle.
- Never install or manipulate wiring during electrical storms.
- Never install electrical jacks in wet locations unless the jacks are specifically designed for wet environments.
- Operate the device only when it is properly grounded.
- Follow the instructions in this guide to properly ground the device to earth.
- Replace fuses only with fuses of the same type and rating.
- Do not open or remove chassis covers or sheet-metal parts unless instructions are provided in the hardware documentation for this device. Such an action could cause severe electrical shock.
- Do not push or force any objects through any opening in the chassis frame. Such an action could result in electrical shock or fire.
- Avoid spilling liquid onto the chassis or onto any device component. Such an action could cause electrical shock or damage the device.
- Avoid touching uninsulated electrical wires or terminals that have not been disconnected from their power source. Such an action could cause electrical shock.

- Some parts of the chassis, including AC and DC power supply surfaces, power supply unit handles, SFB card handles, and fan tray handles might become hot. The following label provides the warning for hot surfaces on the chassis:



- Always ensure that all modules, power supplies, and cover panels are fully inserted and that the installation screws are fully tightened.

Definitions of Safety Warning Levels

The documentation uses the following levels of safety warnings (there are two *Warning* formats):

NOTE: You might find this information helpful in a particular situation, or you might overlook this important information if it was not highlighted in a Note.



CAUTION: You need to observe the specified guidelines to prevent minor injury or discomfort to you or severe damage to the device.

Attention Veillez à respecter les consignes indiquées pour éviter toute incommodité ou blessure légère, voire des dégâts graves pour l'appareil.



LASER WARNING: This symbol alerts you to the risk of personal injury from a laser.

Avertissement Ce symbole signale un risque de blessure provoquée par rayon laser.



WARNING: This symbol means danger. You are in a situation that could cause bodily injury. Before you work on any equipment, be aware of the hazards involved with electrical circuitry, and familiarize yourself with standard practices for preventing accidents.

Waarschuwing Dit waarschuwingssymbool betekent gevaar. U verkeert in een situatie die lichamelijk letsel kan veroorzaken. Voordat u aan enige apparatuur gaat werken, dient u zich bewust te zijn van de bij elektrische schakelingen betrokken risico's en dient u op de hoogte te zijn van standaard maatregelen om ongelukken te voorkomen.

Varoitus Tämä varoitusmerkki merkitsee vaaraa. Olet tilanteessa, joka voi johtaa ruumiinvammaan. Ennen kuin työskentelet minkään laitteiston parissa, ota selvää sähkökytkentöihin liittyvistä vaaroista ja tavanomaisista onnettomuuksien ehkäisykeinoista.

Avertissement Ce symbole d'avertissement indique un danger. Vous vous trouvez dans une situation pouvant causer des blessures ou des dommages corporels. Avant de travailler sur un équipement, soyez conscient des dangers posés par les circuits électriques et familiarisez-vous avec les procédures couramment utilisées pour éviter les accidents.

Warnung Dieses Warnsymbol bedeutet Gefahr. Sie befinden sich in einer Situation, die zu einer Körperverletzung führen könnte. Bevor Sie mit der Arbeit an irgendeinem Gerät beginnen, seien Sie sich der mit elektrischen Stromkreisen verbundenen Gefahren und der Standardpraktiken zur Vermeidung von Unfällen bewusst.

Avvertenza Questo simbolo di avvertenza indica un pericolo. La situazione potrebbe causare infortuni alle persone. Prima di lavorare su qualsiasi apparecchiatura, occorre conoscere i pericoli relativi ai circuiti elettrici ed essere al corrente delle pratiche standard per la prevenzione di incidenti.

Advarsel Dette varselsymbolet betyr fare. Du befinner deg i en situasjon som kan føre til personskade. Før du utfører arbeid på utstyr, må du være oppmerksom på de faremomentene som elektriske kretser innebærer, samt gjøre deg kjent med vanlig praksis når det gjelder å unngå ulykker.

Aviso Este símbolo de aviso indica perigo. Encontra-se numa situação que lhe poderá causar danos físicos. Antes de começar a trabalhar com qualquer equipamento, familiarize-se com os perigos relacionados com circuitos eléctricos, e com quaisquer práticas comuns que possam prevenir possíveis acidentes.

¡Atención! Este símbolo de aviso significa peligro. Existe riesgo para su integridad física. Antes de manipular cualquier equipo, considerar los riesgos que entraña la corriente eléctrica y familiarizarse con los procedimientos estándar de prevención de accidentes.

Varning! Denna varningssymbol signalerar fara. Du befinner dig i en situation som kan leda till personskada. Innan du utför arbete på någon utrustning måste du vara medveten om farorna med elkretsar och känna till vanligt förfarande för att förebygga skador.

Qualified Personnel Warning



WARNING: Only trained and qualified personnel should install or replace the device.

Waarschuwing Installatie en reparaties mogen uitsluitend door getraind en bevoegd personeel uitgevoerd worden.

Varoitus Ainoastaan koulutettu ja pätevä henkilökunta saa asentaa tai vaihtaa tämän laitteen.

Avertissement Tout installation ou remplacement de l'appareil doit être réalisé par du personnel qualifié et compétent.

Warnung Gerät nur von geschultem, qualifiziertem Personal installieren oder auswechseln lassen.

Avvertenza Solo personale addestrato e qualificato deve essere autorizzato ad installare o sostituire questo apparecchio.

Advarsel Kun kvalifisert personell med riktig opplæring bør montere eller bytte ut dette utstyret.

Aviso Este equipamento deverá ser instalado ou substituído apenas por pessoal devidamente treinado e qualificado.

¡Atención! Estos equipos deben ser instalados y reemplazados exclusivamente por personal técnico adecuadamente preparado y capacitado.

Varning! Denna utrustning ska endast installeras och bytas ut av utbildad och kvalificerad personal.

Warning Statement for Norway and Sweden



WARNING: The equipment must be connected to an earthed mains socket-outlet.

Advarsel Apparatet skal kobles til en jordet stikkontakt.

Varning! Apparaten skall anslutas till jordat nätuttag.

Fire Safety Requirements

IN THIS SECTION

- [Fire Suppression | 143](#)
- [Fire Suppression Equipment | 143](#)

In the event of a fire emergency, the safety of people is the primary concern. You should establish procedures for protecting people in the event of a fire emergency, provide safety training, and properly provision fire-control equipment and fire extinguishers.

In addition, you should establish procedures to protect your equipment in the event of a fire emergency. Juniper Networks products should be installed in an environment suitable for electronic equipment. We recommend that fire suppression equipment be available in the event of a fire in the vicinity of the equipment and that all local fire, safety, and electrical codes and ordinances be observed when you install and operate your equipment.

Fire Suppression

In the event of an electrical hazard or an electrical fire, you should first turn power off to the equipment at the source. Then use a Type C fire extinguisher, which uses noncorrosive fire retardants, to extinguish the fire.

Fire Suppression Equipment

Type C fire extinguishers, which use noncorrosive fire retardants such as carbon dioxide and Halotron™, are most effective for suppressing electrical fires. Type C fire extinguishers displace oxygen from the point of combustion to eliminate the fire. For extinguishing fire on or around equipment that draws air from the environment for cooling, you should use this type of inert oxygen displacement extinguisher instead of an extinguisher that leaves residues on equipment.

Do not use multipurpose Type ABC chemical fire extinguishers (dry chemical fire extinguishers). The primary ingredient in these fire extinguishers is monoammonium phosphate, which is very sticky and

difficult to clean. In addition, in the presence of minute amounts of moisture, monoammonium phosphate can become highly corrosive and corrodes most metals.

Any equipment in a room in which a chemical fire extinguisher has been discharged is subject to premature failure and unreliable operation. The equipment is considered to be irreparably damaged.

NOTE: To keep warranties effective, do not use a dry chemical fire extinguisher to control a fire at or near a Juniper Networks device. If a dry chemical fire extinguisher is used, the unit is no longer eligible for coverage under a service agreement.

We recommend that you dispose of any irreparably damaged equipment in an environmentally responsible manner.

Installation Instructions Warning



WARNING: Read the installation instructions before you connect the device to a power source.

Waarschuwing Raadpleeg de installatie-aanwijzingen voordat u het systeem met de voeding verbindt.

Varoitus Lue asennusohjeet ennen järjestelmän yhdistämistä virtälähteeseen.

Avertissement Avant de brancher le système sur la source d'alimentation, consulter les directives d'installation.

Warnung Lesen Sie die Installationsanweisungen, bevor Sie das System an die Stromquelle anschließen.

Avvertenza Consultare le istruzioni di installazione prima di collegare il sistema all'alimentatore.

Advarsel Les installasjonsinstruksjonene før systemet kobles til strømkilden.

Aviso Leia as instruções de instalação antes de ligar o sistema à sua fonte de energia.

¡Atención! Ver las instrucciones de instalación antes de conectar el sistema a la red de alimentación.

Varning! Läs installationsanvisningarna innan du kopplar systemet till dess strömförsörjningsenhet.

Chassis Lifting Guidelines for NFX150 Devices

The weight of an NFX150 device is approximately 9.4 lb (4.3 kg). Observe the following guidelines for lifting and moving an NFX150 device:

- Before installing the device, verify that the intended site meets the specified power, environmental, and clearance requirements.
- Before lifting or moving the switch, disconnect all external cables.

RELATED DOCUMENTATION

General Safety Guidelines and Warnings

Installation Instructions Warning

Restricted Access Warning



WARNING: This unit is intended for installation in restricted access areas. A restricted access area is an area to which access can be gained only by service personnel through the use of a special tool, lock and key, or other means of security, and which is controlled by the authority responsible for the location.

Waarschuwing Dit toestel is bedoeld voor installatie op plaatsen met beperkte toegang. Een plaats met beperkte toegang is een plaats waar toegang slechts door servicepersoneel verkregen kan worden door middel van een speciaal instrument, een slot en sleutel, of een ander veiligheidsmiddel, en welke beheerd wordt door de overheidsinstantie die verantwoordelijk is voor de locatie.

Varoitus Tämä laite on tarkoitettu asennettavaksi paikkaan, johon pääsy on rajoitettua. Paikka, johon pääsy on rajoitettua, tarkoittaa paikkaa, johon vain huoltohenkilöstö pääsee jonkin erikoistyökalun, lukkoon sopivan avaimen tai jonkin muun turvalaitteen avulla ja joka on paikasta vastuussa olevien toimivaltaisten henkilöiden valvoma.

Avertissement Cet appareil est à installer dans des zones d'accès réservé. Ces dernières sont des zones auxquelles seul le personnel de service peut accéder en utilisant un outil spécial, un mécanisme de verrouillage et une clé, ou tout autre moyen de sécurité.

L'accès aux zones de sécurité est sous le contrôle de l'autorité responsable de l'emplacement.

Warnung Diese Einheit ist zur Installation in Bereichen mit beschränktem Zutritt vorgesehen. Ein Bereich mit beschränktem Zutritt ist ein Bereich, zu dem nur Wartungspersonal mit einem Spezialwerkzeugs, Schloß und Schlüssel oder anderer Sicherheitsvorkehrungen Zugang hat, und der von dem für die Anlage zuständigen Gremium kontrolliert wird.

Avvertenza Questa unità deve essere installata in un'area ad accesso limitato. Un'area ad accesso limitato è un'area accessibile solo a personale di assistenza tramite un'attrezzo speciale, lucchetto, o altri dispositivi di sicurezza, ed è controllata dall'autorità responsabile della zona.

Advarsel Denne enheten er laget for installasjon i områder med begrenset adgang. Et område med begrenset adgang gir kun adgang til servicepersonale som bruker et spesielt verktøy, lås og nøkkel, eller en annen sikkerhetsanordning, og det kontrolleres av den autoriteten som er ansvarlig for området.

Aviso Esta unidade foi concebida para instalação em áreas de acesso restrito. Uma área de acesso restrito é uma área à qual apenas tem acesso o pessoal de serviço autorizado, que possua uma ferramenta, chave e fechadura especial, ou qualquer outra forma de segurança. Esta área é controlada pela autoridade responsável pelo local.

¡Atención! Esta unidad ha sido diseñada para instalarse en áreas de acceso restringido. Área de acceso restringido significa un área a la que solamente tiene acceso el personal de servicio mediante la utilización de una herramienta especial, cerradura con llave, o algún otro medio de seguridad, y que está bajo el control de la autoridad responsable del local.

Warning! Denna enhet är avsedd för installation i områden med begränsat tillträde. Ett område med begränsat tillträde får endast tillträdas av servicepersonal med ett speciellt verktyg, lås och nyckel, eller annan säkerhetsanordning, och kontrolleras av den auktoritet som ansvarar för området.

Ramp Warning



WARNING: When installing the device, do not use a ramp inclined at more than 10 degrees.

Waarschuwing Gebruik een oprijplaat niet onder een hoek van meer dan 10 graden.

Varoitus Älä käytä sellaista kaltevaa pintaa, jonka kaltevuus ylittää 10 astetta.

Avertissement Ne pas utiliser une rampe dont l'inclinaison est supérieure à 10 degrés.

Warnung Keine Rampen mit einer Neigung von mehr als 10 Grad verwenden.

Avvertenza Non usare una rampa con pendenza superiore a 10 gradi.

Advarsel Bruk aldri en rampe som heller mer enn 10 grader.

Aviso Não utilize uma rampa com uma inclinação superior a 10 graus.

¡Atención! No usar una rampa inclinada más de 10 grados.

Varning! Använd inte ramp med en lutning på mer än 10 grader.

Rack-Mounting and Cabinet-Mounting Warnings

Ensure that the rack or cabinet in which the device is installed is evenly and securely supported. Uneven mechanical loading could lead to a hazardous condition.



WARNING: To prevent bodily injury when mounting or servicing the device in a rack, take the following precautions to ensure that the system remains stable. The following directives help maintain your safety:

- Install the device in a rack that is secured to the building structure.
- Mount the device at the bottom of the rack if it is the only unit in the rack.
- When mounting the device on a partially filled rack, load the rack from the bottom to the top, with the heaviest component at the bottom of the rack.
- If the rack is provided with stabilizing equipment, install the stabilizers before mounting or servicing the device in the rack.

Waarschuwing Om lichamelijk letsel te voorkomen wanneer u dit toestel in een rek monteert of het daar een servicebeurt geeft, moet u speciale voorzorgsmaatregelen nemen om ervoor te zorgen dat het toestel stabiel blijft. De onderstaande richtlijnen worden verstrekt om uw veiligheid te verzekeren:

- De Juniper Networks switch moet in een stellage worden geïnstalleerd die aan een bouwsel is verankerd.
- Dit toestel dient onderaan in het rek gemonteerd te worden als het toestel het enige in het rek is.
- Wanneer u dit toestel in een gedeeltelijk gevuld rek monteert, dient u het rek van onderen naar boven te laden met het zwaarste onderdeel onderaan in het rek.
- Als het rek voorzien is van stabiliseringshulpmiddelen, dient u de stabilisatoren te monteren voordat u het toestel in het rek monteert of het daar een servicebeurt geeft.

Varoitus Kun laite asetetaan telineeseen tai huolletaan sen ollessa telineessä, on noudatettava erityisiä varotoimia järjestelmän vakavuuden säilyttämiseksi, jotta vältytään loukkaantumiselta. Noudata seuraavia turvallisuusohjeita:

- Juniper Networks switch on asennettava telineeseen, joka on kiinnitetty rakennukseen.
- Jos telineessä ei ole muita laitteita, aseta laite telineen alaosaan.
- Jos laite asetetaan osaksi täytettyyn telineeseen, aloita kuormittaminen sen alaosasta kaikkein raskaimmalla esineellä ja siirry sitten sen yläosaan.
- Jos telinettä varten on vakaimet, asenna ne ennen laitteen asettamista telineeseen tai sen huoltamista siinä.

Avertissement Pour éviter toute blessure corporelle pendant les opérations de montage ou de réparation de cette unité en casier, il convient de prendre des précautions spéciales afin de maintenir la stabilité du système. Les directives ci-dessous sont destinées à assurer la protection du personnel:

- Le rack sur lequel est monté le Juniper Networks switch doit être fixé à la structure du bâtiment.
- Si cette unité constitue la seule unité montée en casier, elle doit être placée dans le bas.
- Si cette unité est montée dans un casier partiellement rempli, charger le casier de bas en haut en plaçant l'élément le plus lourd dans le bas.
- Si le casier est équipé de dispositifs stabilisateurs, installer les stabilisateurs avant de monter ou de réparer l'unité en casier.

Warnung Zur Vermeidung von Körperverletzung beim Anbringen oder Warten dieser Einheit in einem Gestell müssen Sie besondere Vorkehrungen treffen, um sicherzustellen, daß das System stabil bleibt. Die folgenden Richtlinien sollen zur Gewährleistung Ihrer Sicherheit dienen:

- Der Juniper Networks switch muß in einem Gestell installiert werden, das in der Gebäudestruktur verankert ist.
- Wenn diese Einheit die einzige im Gestell ist, sollte sie unten im Gestell angebracht werden.
- Bei Anbringung dieser Einheit in einem zum Teil gefüllten Gestell ist das Gestell von unten nach oben zu laden, wobei das schwerste Bauteil unten im Gestell anzubringen ist.
- Wird das Gestell mit Stabilisierungszubehör geliefert, sind zuerst die Stabilisatoren zu installieren, bevor Sie die Einheit im Gestell anbringen oder sie warten.

Avvertenza Per evitare infortuni fisici durante il montaggio o la manutenzione di questa unità in un supporto, occorre osservare speciali precauzioni per garantire che il sistema rimanga stabile. Le seguenti direttive vengono fornite per garantire la sicurezza personale:

- Il Juniper Networks switch deve essere installato in un telaio, il quale deve essere fissato alla struttura dell'edificio.
- Questa unità deve venire montata sul fondo del supporto, se si tratta dell'unica unità da montare nel supporto.
- Quando questa unità viene montata in un supporto parzialmente pieno, caricare il supporto dal basso all'alto, con il componente più pesante sistemato sul fondo del supporto.
- Se il supporto è dotato di dispositivi stabilizzanti, installare tali dispositivi prima di montare o di procedere alla manutenzione dell'unità nel supporto.

Advarsel Unngå fysiske skader under montering eller reparasjonsarbeid på denne enheten når den befinner seg i et kabinett. Vær nøye med at systemet er stabilt. Følgende retningslinjer er gitt for å verne om sikkerheten:

- Juniper Networks switch må installeres i et stativ som er forankret til bygningsstrukturen.

- Denne enheten bør monteres nederst i kabinettet hvis dette er den eneste enheten i kabinettet.
- Ved montering av denne enheten i et kabinett som er delvis fylt, skal kabinettet lastes fra bunnen og opp med den tyngste komponenten nederst i kabinettet.
- Hvis kabinettet er utstyrt med stabiliseringsutstyr, skal stabilisatorene installeres før montering eller utføring av reparasjonsarbeid på enheten i kabinettet.

Aviso Para se prevenir contra danos corporais ao montar ou reparar esta unidade numa estante, deverá tomar precauções especiais para se certificar de que o sistema possui um suporte estável. As seguintes directrizes ajudá-lo-ão a efectuar o seu trabalho com segurança:

- O Juniper Networks switch deverá ser instalado numa prateleira fixa à estrutura do edifício.
- Esta unidade deverá ser montada na parte inferior da estante, caso seja esta a única unidade a ser montada.
- Ao montar esta unidade numa estante parcialmente ocupada, coloque os itens mais pesados na parte inferior da estante, arrumando-os de baixo para cima.
- Se a estante possuir um dispositivo de estabilização, instale-o antes de montar ou reparar a unidade.

¡Atención! Para evitar lesiones durante el montaje de este equipo sobre un bastidor, oerriormente durante su mantenimiento, se debe poner mucho cuidado en que el sistema quede bien estable. Para garantizar su seguridad, proceda según las siguientes instrucciones:

- El Juniper Networks switch debe instalarse en un bastidor fijado a la estructura del edificio.
- Colocar el equipo en la parte inferior del bastidor, cuando sea la única unidad en el mismo.
- Cuando este equipo se vaya a instalar en un bastidor parcialmente ocupado, comenzar la instalación desde la parte inferior hacia la superior colocando el equipo más pesado en la parte inferior.
- Si el bastidor dispone de dispositivos estabilizadores, instalar éstos antes de montar o proceder al mantenimiento del equipo instalado en el bastidor.

Warning! För att undvika kroppsskada när du installerar eller utför underhållsarbete på denna enhet på en ställning måste du vidta särskilda försiktighetsåtgärder för att försäkra dig om att systemet står stadigt. Följande riktlinjer ges för att trygga din säkerhet:

- Juniper Networks switch måste installeras i en ställning som är förankrad i byggnadens struktur.
- Om denna enhet är den enda enheten på ställningen skall den installeras längst ned på ställningen.
- Om denna enhet installeras på en delvis fylld ställning skall ställningen fyllas nedifrån och upp, med de tyngsta enheterna längst ned på ställningen.
- Om ställningen är försedd med stabiliseringsdon skall dessa monteras fast innan enheten installeras eller underhålls på ställningen.

Laser and LED Safety Guidelines and Warnings for the NFX150 Devices

IN THIS SECTION

- [General Laser Safety Guidelines | 152](#)
- [Class 1M Laser Product Warning | 152](#)
- [Class 1M Laser Radiation Warning | 153](#)
- [Class 1 Laser Product Warning | 153](#)
- [Class 1 LED Product Warning | 154](#)
- [Laser Beam Warning | 154](#)
- [Unterminated Fiber-Optic Cable Warning | 155](#)

NFX150 devices are equipped with laser transmitters:

- SFP and SFP+ transceivers are classified as Class 1 Laser Products (complies with 21 CFR 1040.10 and 1040.11 except for deviations pursuant to Laser Notice 50, dated July 26, 2001) or Class 1 LED Products.

Observe the following guidelines and warnings:

General Laser Safety Guidelines

When working around ports that support optical transceivers, observe the following safety guidelines to prevent eye injury:

- Do not look into unterminated ports or at fibers that connect to unknown sources.
- Do not examine unterminated optical ports with optical instruments.
- Avoid direct exposure to the beam.



LASER WARNING: Unterminated optical connectors can emit invisible laser radiation. The lens in the human eye focuses all the laser power on the retina, so focusing the eye directly on a laser source—even a low-power laser—could permanently damage the eye.

Class 1M Laser Product Warning



LASER WARNING: Class 1M laser product.

Waarschuwing Laserproducten van Klasse 1M (IEC).

Varoitus Luokan 1M (IEC) lasertuotteita.

Attention Produits laser catégorie 1M (IEC).

Warnung Laserprodukte der Klasse 1M (IEC).

Avvertenza Prodotti laser di Classe 1M (IEC).

Advarel Klasse 1M (IEC) laserprodukter.

Aviso Produtos laser Classe 1M (IEC).

¡Atención! Productos láser de Clase 1M (IEC).

Varning! Laserprodukter av Klass 1M (IEC).

Class 1M Laser Radiation Warning



LASER WARNING: Class 1M laser radiation when open. Do not view directly with optical instruments.

Class 1 Laser Product Warning



LASER WARNING: Class 1 laser product.

Waarschuwing Klasse-1 laser produkt.

Varoitus Luokan 1 lasertuote.

Attention Produit laser de classe I.

Warnung Laserprodukt der Klasse 1.

Avvertenza Prodotto laser di Classe 1.

Advarsel Laserprodukt av klasse 1.

Aviso Produto laser de classe 1.

¡Atención! Producto láser Clase I.

Varning! Laserprodukt av klass 1.

Class 1 LED Product Warning



LASER WARNING: Class 1 LED product.

Waarschuwing Klasse 1 LED-product.

Varoitus Luokan 1 valodiodituote.

Attention Alarme de produit LED Class I.

Warnung Class 1 LED-Produktwarnung.

Avvertenza Avvertenza prodotto LED di Classe 1.

Advarel LED-produkt i klasse 1.

Aviso Produto de classe 1 com LED.

¡Atención! Aviso sobre producto LED de Clase 1.

Varning! Lysdiodprodukt av klass 1.

Laser Beam Warning



LASER WARNING: Do not stare into the laser beam or view it directly with optical instruments.

Waarschuwing Niet in de straal staren of hem rechtstreeks bekijken met optische instrumenten.

Varoitus Älä katso säteeseen äläkä tarkastele sitä suoraan optisen laitteen avulla.

Attention Ne pas fixer le faisceau des yeux, ni l'observer directement à l'aide d'instruments optiques.

Warnung Nicht direkt in den Strahl blicken und ihn nicht direkt mit optischen Geräten prüfen.

Avvertenza Non fissare il raggio con gli occhi né usare strumenti ottici per osservarlo direttamente.

Advarel Stirr eller se ikke direkte p strlen med optiske instrumenter.

Aviso Não olhe fixamente para o raio, nem olhe para ele directamente com instrumentos ópticos.

¡Atención! No mirar fijamente el haz ni observarlo directamente con instrumentos ópticos.

Warning! Rikta inte blicken in mot strålen och titta inte direkt på den genom optiska instrument.

Unterminated Fiber-Optic Cable Warning



WARNING: Invisible laser radiation might be emitted from the unterminated connector of a fiber-optic cable. To avoid injury to your eye, do not view the fiber optics with a magnifying optical device, such as a loupe, within 100 mm.

Waarschuwing Er kunnen onzichtbare laserstralen worden uitgezonden vanuit het uiteinde van de onafgebroken vezelkabel of connector. Niet in de straal kijken of deze rechtstreeks bekijken met optische instrumenten. Als u de laseruitvoer met bepaalde optische instrumenten bekijkt (zoals bijv. een oogloep, vergrootglas of microscoop) binnen een afstand van 100 mm kan dit gevaar voor uw ogen opleveren.

Varoitus Päättämättömän kuitukaapelin tai -liittimen päästä voi tulla näkymätöntä lasersäteilyä. Älä tuijota sädettä tai katso sitä suoraan optisilla välineillä. Lasersäteen katsominen tietyillä optisilla välineillä (esim. suurennuslasilla tai mikroskoopilla) 10 cm:n päästä tai sitä lähempää voi olla vaarallista silmille.

Attention Des émissions de radiations laser invisibles peuvent se produire à l'extrémité d'un câble en fibre ou d'un raccord sans terminaison. Ne pas fixer du regard le rayon ou l'observer directement avec des instruments optiques. L'observation du laser à l'aide certains instruments optiques (loupes et microscopes) à une distance inférieure à 100 mm peut poser des risques pour les yeux.

Warnung Eine unsichtbare Laserstrahlung kann vom Ende des nicht angeschlossenen Glasfaserkabels oder Steckers ausgestrahlt werden. Nicht in den Laserstrahl schauen oder diesen mit einem optischen Instrument direkt ansehen. Ein Betrachten des Laserstrahls mit bestimmten optischen Instrumenten, wie z.B. Augenlupen, Vergrößerungsgläsern und Mikroskopen innerhalb eines Abstands von 100 mm kann für das Auge gefährlich sein.

Avvertenza L'estremità del connettore o del cavo ottico senza terminazione può emettere radiazioni laser invisibili. Non fissare il raggio od osservarlo in modo diretto con strumenti ottici. L'osservazione del fascio laser con determinati strumenti ottici (come lupette, lenti di ingrandimento o microscopi) entro una distanza di 100 mm può provocare danni agli occhi.

Advarsel Usynlig laserstråling kan emitte fra enden av den ikke-terminerte fiberkabelen eller koblingen. Ikke se inn i strålen og se heller ikke direkte på strålen med optiske instrumenter. Observering av laserutgang med visse optiske instrumenter (for eksempel øyelupe, forstørrelsesglass eller mikroskoper) innenfor en avstand på 100 mm kan være farlig for øynene.

Aviso Radiação laser invisível pode ser emitida pela ponta de um conector ou cabo de fibra não terminado. Não olhe fixa ou diretamente para o feixe ou com instrumentos ópticos. Visualizar a emissão do laser com certos instrumentos ópticos (por exemplo, lupas, lentes de aumento ou microscópios) a uma distância de 100 mm pode causar riscos à visão.

¡Atención! El extremo de un cable o conector de fibra sin terminación puede emitir radiación láser invisible. No se acerque al radio de acción ni lo mire directamente con instrumentos ópticos. La exposición del ojo a una salida de láser con determinados instrumentos ópticos (por ejemplo, lupas y microscopios) a una distancia de 100 mm puede comportar lesiones oculares.

Varning! Osynlig laserstrålning kan komma från änden på en oavslutad fiberkabel eller -anslutning. Titta inte rakt in i strålen eller direkt på den med optiska instrument. Att titta på laserstrålen med vissa optiska instrument (t.ex. lupper, förstoringsglas och mikroskop) från ett avstånd på 100 mm kan skada ögonen.

RELATED DOCUMENTATION

General Safety Guidelines and Warnings

Radiation from Open Port Apertures Warning

Installation Instructions Warning

Grounded Equipment Warning

Radiation from Open Port Apertures Warning



LASER WARNING: Because invisible radiation might be emitted from the aperture of the port when no fiber cable is connected, avoid exposure to radiation and do not stare into open apertures.

Waarschuwing Aangezien onzichtbare straling vanuit de opening van de poort kan komen als er geen fiberkabel aangesloten is, dient blootstelling aan straling en het kijken in open openingen vermeden te worden.

Varoitus Koska portin aukosta voi emittoitua näkymätöntä säteilyä, kun kuitukaapelia ei ole kytkettynä, vältä säteilylle altistumista äläkä katso avoimiin aukkoihin.

Avertissement Des radiations invisibles à l'il nu pouvant traverser l'ouverture du port lorsqu'aucun câble en fibre optique n'y est connecté, il est recommandé de ne pas regarder fixement l'intérieur de ces ouvertures.

Warnung Aus der Port-Öffnung können unsichtbare Strahlen emittieren, wenn kein Glasfaserkabel angeschlossen ist. Vermeiden Sie es, sich den Strahlungen auszusetzen, und starren Sie nicht in die Öffnungen!

Avvertenza Quando i cavi in fibra non sono inseriti, radiazioni invisibili possono essere emesse attraverso l'apertura della porta. Evitate di esporvi alle radiazioni e non guardate direttamente nelle aperture.

Advarsel Unngå utsettelse for stråling, og stirr ikke inn i åpninger som er åpne, fordi usynlig stråling kan emitteres fra portens åpning når det ikke er tilkoblet en fiberkabel.

Aviso Dada a possibilidade de emissão de radiação invisível através do orifício da via de acesso, quando esta não tiver nenhum cabo de fibra conectado, deverá evitar a exposição à radiação e não deverá olhar fixamente para orifícios que se encontrarem a descoberto.

¡Atención! Debido a que la apertura del puerto puede emitir radiación invisible cuando no existe un cable de fibra conectado, evite mirar directamente a las aperturas para no exponerse a la radiación.

Warning! Osynlig strålning kan avges från en portöppning utan ansluten fiberkabel och du bör därför undvika att bli utsatt för strålning genom att inte stirra in i oskyddade öppningar.

Maintenance and Operational Safety Guidelines and Warnings

IN THIS SECTION

- Battery Handling Warning | 158
- Jewelry Removal Warning | 159
- Lightning Activity Warning | 161
- Operating Temperature Warning | 161
- Product Disposal Warning | 163

While performing the maintenance activities for devices, observe the following guidelines and warnings:

Battery Handling Warning



WARNING: Replacing a battery incorrectly might result in an explosion. Replace a battery only with the same or equivalent type recommended by the manufacturer. Dispose of used batteries according to the manufacturer's instructions.

Waarschuwing Er is ontploffingsgevaar als de batterij verkeerd vervangen wordt. Vervang de batterij slechts met hetzelfde of een equivalent type dat door de fabrikant aanbevolen is. Gebruikte batterijen dienen overeenkomstig fabrieksvoorschriften weggegooid te worden.

Varoitus Räjähdyksen vaara, jos akku on vaihdettu väärään akkuun. Käytä vaihtamiseen ainoastaan saman- tai vastaavatyypistä akkua, joka on valmistajan suosittelema. Hävitä käytetyt akut valmistajan ohjeiden mukaan.

Avertissement Danger d'explosion si la pile n'est pas remplacée correctement. Ne la remplacer que par une pile de type semblable ou équivalent, recommandée par le fabricant. Jeter les piles usagées conformément aux instructions du fabricant.

Warnung Bei Einsetzen einer falschen Batterie besteht Explosionsgefahr. Ersetzen Sie die Batterie nur durch den gleichen oder vom Hersteller empfohlenen Batterietyp. Entsorgen Sie die benutzten Batterien nach den Anweisungen des Herstellers.

Advarsel Det kan være fare for eksplosjon hvis batteriet skiftes på feil måte. Skift kun med samme eller tilsvarende type som er anbefalt av produsenten. Kasser brukte batterier i henhold til produsentens instruksjoner.

Avvertenza Pericolo di esplosione se la batteria non è installata correttamente. Sostituire solo con una di tipo uguale o equivalente, consigliata dal produttore. Eliminare le batterie usate secondo le istruzioni del produttore.

Aviso Existe perigo de explosão se a bateria for substituída incorrectamente. Substitua a bateria por uma bateria igual ou de um tipo equivalente recomendado pelo fabricante. Destrua as baterias usadas conforme as instruções do fabricante.

¡Atención! Existe peligro de explosión si la batería se reemplaza de manera incorrecta. Reemplazar la batería EXclusivamente con el mismo tipo o el equivalente recomendado por el fabricante. Desechar las baterías gastadas según las instrucciones del fabricante.

Varning! Explosionsfara vid felaktigt batteribyte. Ersätt endast batteriet med samma batterityp som rekommenderas av tillverkaren eller motsvarande. Följ tillverkarens anvisningar vid kassering av använda batterier.

Jewelry Removal Warning



WARNING: Before working on equipment that is connected to power lines, remove jewelry, including rings, necklaces, and watches. Metal objects heat up when connected to power and ground and can cause serious burns or can be welded to the terminals.

Waarschuwing Alvorens aan apparatuur te werken die met elektrische leidingen is verbonden, sieraden (inclusief ringen, kettingen en horloges) verwijderen. Metalen voorwerpen worden warm wanneer ze met stroom en aarde zijn verbonden, en kunnen ernstige brandwonden veroorzaken of het metalen voorwerp aan de aansluitklemmen lassen.

Varoitus Ennen kuin työskentelet voimavirtajohtoihin kytkettyjen laitteiden parissa, ota pois kaikki korut (sormukset, kaulakorut ja kellot mukaan lukien). Metalliesineet

kuumenevat, kun ne ovat yhteydessä sähkövirran ja maan kanssa, ja ne voivat aiheuttaa vakavia palovammoja tai hitsata metalliesineet kiinni liitännänapoihin.

Avertissement Avant d'accéder à cet équipement connecté aux lignes électriques, ôter tout bijou (anneaux, colliers et montres compris). Lorsqu'ils sont branchés à l'alimentation et reliés à la terre, les objets métalliques chauffent, ce qui peut provoquer des blessures graves ou souder l'objet métallique aux bornes.

Warnung Vor der Arbeit an Geräten, die an das Netz angeschlossen sind, jeglichen Schmuck (einschließlich Ringe, Ketten und Uhren) abnehmen. Metallgegenstände erhitzen sich, wenn sie an das Netz und die Erde angeschlossen werden, und können schwere Verbrennungen verursachen oder an die Anschlußklemmen angeschweißt werden.

Avvertenza Prima di intervenire su apparecchiature collegate alle linee di alimentazione, togliersi qualsiasi monile (inclusi anelli, collane, braccialetti ed orologi). Gli oggetti metallici si riscaldano quando sono collegati tra punti di alimentazione e massa: possono causare ustioni gravi oppure il metallo può saldarsi ai terminali.

Advarsel Fjern alle smykker (inkludert ringer, halskjeder og klokker) før du skal arbeide på utstyr som er koblet til kraftledninger. Metallgjenstander som er koblet til kraftledninger og jord blir svært varme og kan forårsake alvorlige brannskader eller smelte fast til polene.

Aviso Antes de trabalhar em equipamento que esteja ligado a linhas de corrente, retire todas as jóias que estiver a usar (incluindo anéis, fios e relógios). Os objectos metálicos aquecerão em contacto com a corrente e em contacto com a ligação à terra, podendo causar queimaduras graves ou ficarem soldados aos terminais.

¡Atención! Antes de operar sobre equipos conectados a líneas de alimentación, quitarse las joyas (incluidos anillos, collares y relojes). Los objetos de metal se calientan cuando se conectan a la alimentación y a tierra, lo que puede ocasionar quemaduras graves o que los objetos metálicos queden soldados a los bornes.

Varning! Tag av alla smycken (inklusive ringar, halsband och armbandsur) innan du arbetar på utrustning som är kopplad till kraftledningar. Metallobjekt hettas upp när de kopplas ihop med ström och jord och kan förorsaka allvarliga brännskador; metallobjekt kan också sammansvetsas med kontakterna.

Lightning Activity Warning



WARNING: Do not work on the system or connect or disconnect cables during periods of lightning activity.

Waarschuwing Tijdens onweer dat gepaard gaat met bliksem, dient u niet aan het systeem te werken of kabels aan te sluiten of te ontkoppelen.

Varoitus Älä työskentele järjestelmän parissa äläkä yhdistä tai irrota kaapeleita ukkosilmalla.

Avertissement Ne pas travailler sur le système ni brancher ou débrancher les câbles pendant un orage.

Warnung Arbeiten Sie nicht am System und schließen Sie keine Kabel an bzw. trennen Sie keine ab, wenn es gewittert.

Avvertenza Non lavorare sul sistema o collegare oppure scollegare i cavi durante un temporale con fulmini.

Advarsel Utfør aldri arbeid på systemet, eller koble kabler til eller fra systemet når det tordner eller lyner.

Aviso Não trabalhe no sistema ou ligue e desligue cabos durante períodos de mau tempo (trovoada).

¡Atención! No operar el sistema ni conectar o desconectar cables durante el transcurso de descargas eléctricas en la atmósfera.

Varning! Vid åska skall du aldrig utföra arbete på systemet eller ansluta eller koppla loss kablar.

Operating Temperature Warning



WARNING: To prevent the device from overheating, do not operate it in an area that exceeds the maximum recommended ambient temperature. To prevent airflow restriction, allow at least 6 in. (15.2 cm) of clearance around the ventilation openings.

Waarschuwing Om te voorkomen dat welke switch van de Juniper Networks router dan ook oververhit raakt, dient u deze niet te bedienen op een plaats waar de maximale aanbevolen omgevingstemperatuur van 40° C wordt overschreden. Om te voorkomen

dat de luchtstroom wordt beperkt, dient er minstens 15,2 cm speling rond de ventilatieopeningen te zijn.

Varoitus Ettei Juniper Networks switch-sarjan reititin ylikuumentuisi, sitä ei saa käyttää tilassa, jonka lämpötila ylittää korkeimman suositellun ympäristölämpötilan 40° C. Ettei ilmanvaihto estyisi, tuuletusaukkojen ympärille on jätettävä ainakin 15,2 cm tilaa.

Avertissement Pour éviter toute surchauffe des routeurs de la gamme Juniper Networks switch, ne l'utilisez pas dans une zone où la température ambiante est supérieure à 40° C. Pour permettre un flot d'air constant, dégagez un espace d'au moins 15,2 cm autour des ouvertures de ventilations.

Warnung Um einen Router der switch vor Überhitzung zu schützen, darf dieser nicht in einer Gegend betrieben werden, in der die Umgebungstemperatur das empfohlene Maximum von 40° C überschreitet. Um Lüftungsverschluß zu verhindern, achten Sie darauf, daß mindestens 15,2 cm lichter Raum um die Lüftungsöffnungen herum frei bleibt.

Avvertenza Per evitare il surriscaldamento dei switch, non adoperateli in un locale che ecceda la temperatura ambientale massima di 40° C. Per evitare che la circolazione dell'aria sia impedita, lasciate uno spazio di almeno 15.2 cm di fronte alle aperture delle ventole.

Advarsel Unngå overoppheting av eventuelle rutere i Juniper Networks switch Disse skal ikke brukes på steder der den anbefalte maksimale omgivelsestemperaturen overstiger 40° C (104° F). Sørg for at klaringen rundt lufteåpningene er minst 15,2 cm (6 tommer) for å forhindre nedsatt luftsirkulasjon.

Aviso Para evitar o sobreaquecimento do encaminhador Juniper Networks switch, não utilize este equipamento numa área que exceda a temperatura máxima recomendada de 40° C. Para evitar a restrição à circulação de ar, deixe pelo menos um espaço de 15,2 cm à volta das aberturas de ventilação.

¡Atención! Para impedir que un encaminador de la serie Juniper Networks switch se recaliente, no lo haga funcionar en un área en la que se supere la temperatura ambiente máxima recomendada de 40° C. Para impedir la restricción de la entrada de aire, deje un espacio mínimo de 15,2 cm alrededor de las aperturas para ventilación.

Varning! Förhindra att en Juniper Networks switch överhettas genom att inte använda den i ett område där den maximalt rekommenderade omgivningstemperaturen på 40° C överskrids. Förhindra att luftcirkulationen inskränks genom att se till att det finns fritt utrymme på minst 15,2 cm omkring ventilationsöppningarna.

Product Disposal Warning



WARNING: Disposal of this device must be handled according to all national laws and regulations.

Waarschuwing Dit produkt dient volgens alle landelijke wetten en voorschriften te worden afgedankt.

Varoitus Tämän tuotteen lopullisesta hävittämisestä tulee huolehtia kaikkia valtakunnallisia lakeja ja säännöksiä noudattaen.

Avertissement La mise au rebut définitive de ce produit doit être effectuée conformément à toutes les lois et réglementations en vigueur.

Warnung Dieses Produkt muß den geltenden Gesetzen und Vorschriften entsprechend entsorgt werden.

Avvertenza L'eliminazione finale di questo prodotto deve essere eseguita osservando le normative italiane vigenti in materia

Advarsel Endelig disponering av dette produktet må skje i henhold til nasjonale lover og forskrifter.

Aviso A descartagem final deste produto deverá ser efectuada de acordo com os regulamentos e a legislação nacional.

¡Atención! El desecho final de este producto debe realizarse según todas las leyes y regulaciones nacionales

Warning! Slutlig kassering av denna produkt bör skötas i enlighet med landets alla lagar och föreskrifter.

General Electrical Safety Guidelines and Warnings



WARNING: Certain ports on the device are designed for use as intrabuilding (within-the-building) interfaces only (Type 2 or Type 4 ports as described in *GR-1089-CORE*) and require isolation from the exposed outside plant (OSP) cabling. To comply with NEBS (Network Equipment-Building System) requirements and protect against lightning surges and commercial power disturbances, the intrabuilding ports *must not* be metallically connected to interfaces that connect to the OSP or its wiring. The

intrabuilding ports on the device are suitable for connection to intrabuilding or unexposed wiring or cabling only. The addition of primary protectors is not sufficient protection for connecting these interfaces metalically to OSP wiring.

Avertissement Certains ports de l'appareil sont destinés à un usage en intérieur uniquement (ports Type 2 ou Type 4 tels que décrits dans le document *GR-1089-CORE*) et doivent être isolés du câblage de l'installation extérieure exposée. Pour respecter les exigences NEBS et assurer une protection contre la foudre et les perturbations de tension secteur, les ports pour intérieur *ne doivent pas* être raccordés physiquement aux interfaces prévues pour la connexion à l'installation extérieure ou à son câblage. Les ports pour intérieur de l'appareil sont réservés au raccordement de câbles pour intérieur ou non exposés uniquement. L'ajout de protections ne constitue pas une précaution suffisante pour raccorder physiquement ces interfaces au câblage de l'installation extérieure.



CAUTION: Before removing or installing components of a device, connect an electrostatic discharge (ESD) grounding strap to an ESD point and wrap and fasten the other end of the strap around your bare wrist. Failure to use an ESD grounding strap could result in damage to the device.

Attention Avant de retirer ou d'installer des composants d'un appareil, raccordez un bracelet antistatique à un point de décharge électrostatique et fixez le bracelet à votre poignet nu. L'absence de port d'un bracelet antistatique pourrait provoquer des dégâts sur l'appareil.

- Install the device in compliance with the following local, national, and international electrical codes:
 - United States—National Fire Protection Association (NFPA 70), United States National Electrical Code.
 - Other countries—International Electromechanical Commission (IEC) 60364, Part 1 through Part 7.
 - Evaluated to the TN power system.
 - Canada—Canadian Electrical Code, Part 1, CSA C22.1.
 - Suitable for installation in Information Technology Rooms in accordance with Article 645 of the National Electrical Code and NFPA 75.

Peut être installé dans des salles de matériel de traitement de l'information conformément à l'article 645 du National Electrical Code et à la NFPA 75.
- Locate the emergency power-off switch for the room in which you are working so that if an electrical accident occurs, you can quickly turn off the power.

- Make sure that you clean grounding surface and give them a bright finish before making grounding connections.
- Do not work alone if potentially hazardous conditions exist anywhere in your workspace.
- Never assume that power is disconnected from a circuit. Always check the circuit before starting to work.
- Carefully look for possible hazards in your work area, such as moist floors, ungrounded power extension cords, and missing safety grounds.
- Operate the device within marked electrical ratings and product usage instructions.
- To ensure that the device and peripheral equipment function safely and correctly, use the cables and connectors specified for the attached peripheral equipment, and make certain they are in good condition.

You can remove and replace many device components without powering off or disconnecting power to the device, as detailed elsewhere in the hardware documentation for this device. Never install equipment that appears to be damaged.

Action to Take After an Electrical Accident

If an electrical accident results in an injury, take the following actions in this order:

1. Use caution. Be aware of potentially hazardous conditions that could cause further injury.
2. Disconnect power from the device.
3. If possible, send another person to get medical aid. Otherwise, assess the condition of the victim, and then call for help.

Prevention of Electrostatic Discharge Damage

Device components that are shipped in antistatic bags are sensitive to damage from static electricity. Some components can be impaired by voltages as low as 30 V. You can easily generate potentially damaging static voltages whenever you handle plastic or foam packing material or if you move components across plastic or carpets. Observe the following guidelines to minimize the potential for electrostatic discharge (ESD) damage, which can cause intermittent or complete component failures:

- Always use an ESD wrist strap when you are handling components that are subject to ESD damage, and make sure that it is in direct contact with your skin.

If a grounding strap is not available, hold the component in its antistatic bag (see [Figure 51 on page 167](#)) in one hand and touch the exposed, bare metal of the device with the other hand immediately before inserting the component into the device.



WARNING: For safety, periodically check the resistance value of the ESD grounding strap. The measurement must be in the range 1 through 10 Mohms.

Avertissement Par mesure de sécurité, vérifiez régulièrement la résistance du bracelet antistatique. Cette valeur doit être comprise entre 1 et 10 mégohms (Mohms).

- When handling any component that is subject to ESD damage and that is removed from the device, make sure the equipment end of your ESD wrist strap is attached to the ESD point on the chassis.

If no grounding strap is available, touch the exposed, bare metal of the device to ground yourself before handling the component.

- Avoid contact between the component that is subject to ESD damage and your clothing. ESD voltages emitted from clothing can damage components.
- When removing or installing a component that is subject to ESD damage, always place it component-side up on an antistatic surface, in an antistatic card rack, or in an antistatic bag (see [Figure 51 on page 167](#)). If you are returning a component, place it in an antistatic bag before packing it.

Figure 51: Placing a Component into an Antistatic Bag

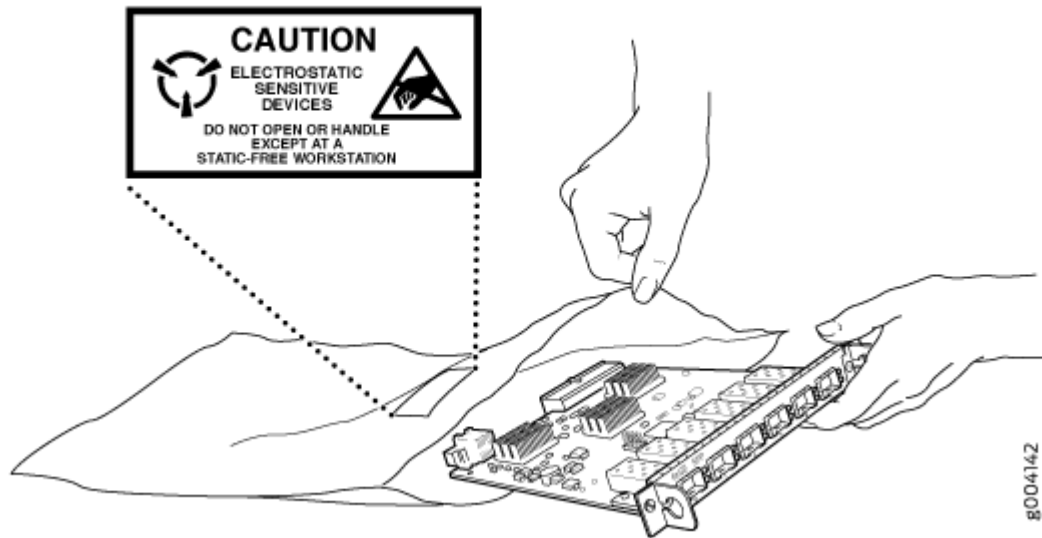

CAUTION: ANSI/TIA/EIA-568 cables such as Category 5e and Category 6 can get electrostatically charged. To dissipate this charge, always ground the cables to a suitable and safe earth ground before connecting them to the system.

Attention Les câbles ANSI/TIA/EIA-568, par exemple Cat 5e et Cat 6, peuvent emmagasiner des charges électrostatiques. Pour évacuer ces charges, reliez toujours les câbles à une prise de terre adaptée avant de les raccorder au système.

AC Power Electrical Safety Guidelines

The following electrical safety guidelines apply to AC-powered devices:

- Note the following warnings printed on the device:

“CAUTION: THIS UNIT HAS MORE THAN ONE POWER SUPPLY CORD. DISCONNECT ALL POWER SUPPLY CORDS BEFORE SERVICING TO AVOID ELECTRIC SHOCK.”

“ATTENTION: CET APPAREIL COMPORTE PLUS D'UN CORDON D'ALIMENTATION. AFIN DE PRÉVENIR LES CHOCS ÉLECTRIQUES, DÉBRANCHER TOUT CORDON D'ALIMENTATION AVANT DE FAIRE LE DÉPANNAGE.”

- AC-powered devices are shipped with a three-wire electrical cord with a grounding-type plug that fits only a grounding-type power outlet. Do not circumvent this safety feature. Equipment grounding must comply with local and national electrical codes.
- You must provide an external certified circuit breaker (2-pole circuit breaker or 4-pole circuit breaker based on your device) rated minimum 20 A in the building installation.
- The power cord serves as the main disconnecting device for the AC-powered device. The socket outlet must be near the AC-powered device and be easily accessible.
- For devices that have more than one power supply connection, you must ensure that all power connections are fully disconnected so that power to the device is completely removed to prevent electric shock. To disconnect power, unplug all power cords (one for each power supply).

Power Cable Warning (Japanese)

WARNING: The attached power cable is only for this product. Do not use the cable for another product.

注意

附属の電源コードセットはこの製品専用です。
他の電気機器には使用しないでください。

0017283

AC Power Disconnection Warning



WARNING: Before working on the device or near power supplies, unplug all the power cords from an AC-powered device.

Waarschuwing Voordat u aan een frame of in de nabijheid van voedingen werkt, dient u bij wisselstroom toestellen de stekker van het netsnoer uit het stopcontact te halen.

Varoitus Kytke irti vaihtovirtalaitteiden virtajohto, ennen kuin teet mitään asennuspohjalle tai työskentelet virtalähteiden läheisyydessä.

Avertissement Avant de travailler sur un châssis ou à proximité d'une alimentation électrique, débrancher le cordon d'alimentation des unités en courant alternatif.

Warnung Bevor Sie an einem Chassis oder in der Nähe von Netzgeräten arbeiten, ziehen Sie bei Wechselstromeinheiten das Netzkabel ab bzw.

Avvertenza Prima di lavorare su un telaio o intorno ad alimentatori, scollegare il cavo di alimentazione sulle unità CA.

Advarsel Før det utføres arbeid på kabinettet eller det arbeides i nærheten av strømforsyningsenheter, skal strømledningen trekkes ut på vekselstrømsenheter.

Aviso Antes de trabalhar num chassis, ou antes de trabalhar perto de unidades de fornecimento de energia, desligue o cabo de alimentação nas unidades de corrente alternada.

¡Atención! Antes de manipular el chasis de un equipo o trabajar cerca de una fuente de alimentación, desenchufar el cable de alimentación en los equipos de corriente alterna (CA).

Varning! Innan du arbetar med ett chassi eller nära strömförsörjningsenheter skall du för växelströmsenheter dra ur nätsladden.

TN Power Warning



WARNING: The device is designed to work with a TN power system.

Waarschuwing Het apparaat is ontworpen om te functioneren met TN energiesystemen.

Varoitus Koje on suunniteltu toimimaan TN-sähkövoimajärjestelmien yhteydessä.

Avertissement Ce dispositif a été conçu pour fonctionner avec des systèmes d'alimentation TN.

Warnung Das Gerät ist für die Verwendung mit TN-Stromsystemen ausgelegt.

Avvertenza Il dispositivo è stato progettato per l'uso con sistemi di alimentazione TN.

Advarsel Utstyret er utfomet til bruk med TN-strømsystemer.

Aviso O dispositivo foi criado para operar com sistemas de corrente TN.

¡Atención! El equipo está diseñado para trabajar con sistemas de alimentación tipo TN.

Varning! Enheten är konstruerad för användning tillsammans med elkraftssystem av TN-typ.

Agency Approvals for NFX150 Devices

IN THIS SECTION

- [Compliance Statement for Argentina | 171](#)

The NFX150 hardware devices comply with the following standards:

- Safety
 - CAN/CSA-C22.2 No. 60950-1 Information Technology Equipment
 - UL 60950-1 Information Technology Equipment
 - EN 60950-1 Information Technology Equipment
 - IEC 60950-1 Information Technology Equipment
 - EN 60825-1 Safety of Laser Products - Part 1: Equipment classification and requirements
- EMC
 - FCC 47CFR Part 15 Class A (USA)
 - EN 55032 Class A Emissions (Europe)
 - ICES-003 Class A (Canada)
 - VCCI Class A (Japan)
 - AS/NZS CISPR 32 Class A (Australia/New Zealand)
 - CISPR 22 Class A
 - CISPR 32 Class A
 - KN 32 (South Korea)

- KN 35 (South Korea)
- EN 55024 (Europe)
- EN 300386 (Europe)
- EN 61000-3-2 Power Line Harmonics
- EN 61000-3-3 Voltage Fluctuations and Flicker
- EN 61000-4-2 ESD
- EN 61000-4-3 Radiated Immunity
- EN 61000-4-4 EFT
- EN 61000-4-5 Surge
- EN 61000-4-6 Low Frequency Common Immunity
- EN 61000-4-11 Voltage Dips and Sags

Compliance Statement for Argentina

EQUIPO DE USO IDÓNEO.

RELATED DOCUMENTATION

[Compliance Statements for EMC Requirements for NFX150 Devices | 171](#)

Compliance Statements for EMC Requirements for NFX150 Devices

IN THIS SECTION

[Canada | 172](#)

- European Community | 173
- Israel | 173
- Japan | 173
- Korea | 174
- United States | 174
- FCC Part 15 Statement | 174

This topic describes the EMC requirements for the NFX150 hardware devices for:

Canada

This Class A digital apparatus complies with Canadian ICES-003.

Cet appareil numérique de la classe A est conforme à la norme NMB-003 du Canada.

The Industry Canada label identifies certified equipment. This certification means that the equipment meets certain telecommunications network protective, operational, and safety requirements. Industry Canada does not guarantee the equipment will operate to the users' satisfaction.

Before installing this equipment, users should ensure that it is permissible to connect the equipment to the facilities of the local telecommunications company. The equipment must also be installed using an acceptable method of connection. In some cases, the inside wiring associated with a single line individual service can be extended by means of a certified connector assembly. The customer should be aware that compliance with the above conditions might not prevent degradation of service in some situations.

Repairs to certified equipment should be made by an authorized Canadian maintenance facility designated by the supplier. Any repairs or alterations made by the user to this equipment, or equipment malfunctions, might give the telecommunications company cause to request the user to disconnect the equipment.



CAUTION: Users should not attempt to make electrical ground connections by themselves, but should contact the appropriate inspection authority or an electrician, as appropriate.

Users should ensure for their own protection that the electrical ground connections of the power utility, telephone lines, and internal metallic water pipe system, if present, are connected together. This precaution might be particularly important in rural areas.

European Community

This is a Class A device. In a domestic environment this device might cause radio interference, in which case the user needs to take adequate measures.

Israel

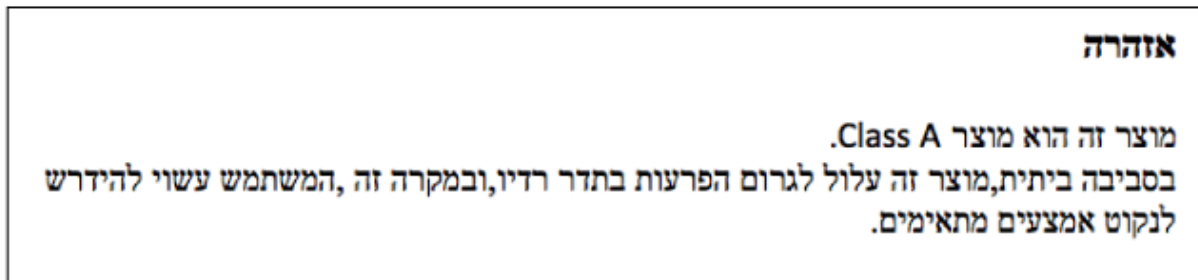

Translation from Hebrew–Warning: This product is Class A. In residential environments, the product may cause radio interference, and in such a situation, the user may be required to take adequate measures.

Japan

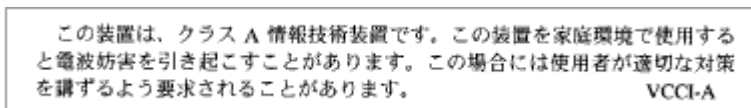

The preceding translates as follows:

This is a Class A device. In a domestic environment this device might cause radio interference, in which case the user needs to take adequate measures.

VCCI-A

Korea

이 기기는 업무용(A급) 전자파적합기기로서 판매자 또는 사용자는 이 점을 주의하시기 바라며, 가정외의 지역에서 사용하는 것을 목적으로 합니다.

Korean Class A Warning

g040913

The preceding translates as follows:

This equipment is Industrial (Class A) electromagnetic wave suitability equipment and seller or user should take notice of it, and this equipment is to be used in the places except for home

United States

The device has been tested and found to comply with the limits for a Class A digital device, pursuant to Part 15 of the FCC Rules. These limits are designed to provide reasonable protection against harmful interference when the equipment is operated in a commercial environment. This equipment generates, uses, and can radiate radio frequency energy and, if not installed and used in accordance with the instruction manual, might cause harmful interference to radio communications. Operation of this equipment in a residential area is likely to cause harmful interference, in which case users need to correct the interference at their own expense.

FCC Part 15 Statement

This equipment has been tested and found to comply with the limits for a Class A digital device pursuant to Part 15 of the FCC Rules. These limits are designed to provide reasonable protection against harmful interference in a residential installation. This equipment generates, uses, and can radiate radio frequency energy and, if not installed and used in accordance with the instructions, might cause harmful interference to radio communications. However, there is no guarantee that interference will not occur in a particular installation.

If this equipment does cause harmful interference to radio or television reception, which can be determined by turning the equipment off and on, the user is encouraged to try and correct the interference by one or more of the following measures:

- Reorient or relocate the receiving antenna.
- Increase the separation between the equipment and the receiver.
- Connect the equipment into an outlet on a circuit different from that to which the receiver is connected.
- Consult the dealer or an experienced radio or TV technician for help.

RELATED DOCUMENTATION

| [Agency Approvals for NFX150 Devices](#) | 170